

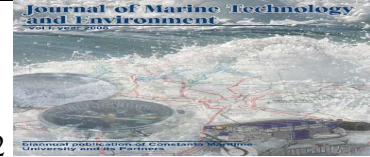

ISSN 1844-6116



**This Journal has been founded in 2008 as a biannual publication of
Constanta Maritime University/ROMANIA**

TOPICS

- Marine Science and Engineering
- Marine Environmental Issues
- Marine Renewable Energy and Sustainability
- Maritime Safety
- Marine Chemistry
- Marine Corrosion and Material Science
- Ship Design, Building Technologies
- Ocean Engineering
- Advanced Technologies for MET
- Advances in numerical methods for marine engineering
- Algorithms for multidisciplinary problems in marine engineering
- Other related topics

Editor in Chief

Mariana PANAITESCU (Constanta Maritime University/ROMANIA)

Vice Editor in Chief

Feiza MEMET (Constanta Maritime University/ROMANIA)

EDITORIAL BOARD

Prof. PhD. Angelica M. BAYLON (Maritime Academy of Asia and the Pacific, Mariveles Bataan, PHILIPPINES)

Prof. VADM Eduardo Ma R SANTOS (Maritime Academy of Asia and the Pacific, Mariveles Bataan, PHILIPPINES)

Dr. Prof. Hu QINYOU (Shanghai Maritime University, Shanghai, CHINA)

Mahmoud Reza HAGHDOSTI (Iran Maritime Training Center, Teheran, IRAN)

DSc., Professor Irina MAKASHINA (International Education Center of Admiral Ushakov State Maritime University, Novorossiysk, RUSSIA)

Prof. PhD. Igor SMIRNOV (Admiral Ushakov Maritime State University, Novorossiysk, RUSSIA)

Prof. PhD. Tomasz NEUMANN (Gdynia Maritime University, Faculty of Navigation, Department of Navigation, POLAND)

Prof. PhD. Axel LUTTENBERGER (University of Rijeka, Faculty of Maritime Studies Rijeka, CROATIA)

Professor of National Security Boyan Kirilov MEDNIKAROV ("Nikola Vaptsarov" Naval Academy, Varna, BULGARIA)

Prof. PhD Eng. Petko Stoyanov PETKOV (University "Prof. Dr. Asen Zlatarov", Burgas, BULGARIA)

Prof. Dr. Nil GULER (Istanbul Technical University, TURKEY)

Prof. PhD. Eng. Gheorghe - Constantin IONESCU (University from Oradea, Faculty of civil engineering and architecture, Department of civil engineering, Oradea, ROMANIA)

Prof. PhD. Eng. Cornel PANAIT (Constanta Maritime University, ROMANIA)

Prof. PhD. Eng. Viorel-Fanel PANAITESCU (Constanta Maritime University, ROMANIA)

Prof. PhD. Eng. Nicolae BUZBUCHI (Constanta Maritime University, ROMANIA)

Prof. PhD. Eng. Dumitru DINU (Constanta Maritime University, ROMANIA)

Prof. PhD. Eng. Dan POPA (Constanta Maritime University, ROMANIA)

Ph.D. Ricardo Rodriguez - MARTOS DAUER (Departament de Ciencia i Enginyeria Nautiques/Universitat Politecnica de Catalunya/SPAIN)

Prof. PhD. Sergii RUDENKO (Odessa National Maritime University/ UKRAINA)

SCIENTIFIC BOARD

Assoc. Prof. Mykola ADAMCHUK (Odessa National Maritime University, UKRAINA)

Dr. Docent Eng. Bohoz APRAHAMIAN (Technical University of Varna, BULGARIA)

Assoc. Prof. PhD. Eugen BARSAN (Constanta Maritime University, ROMANIA)

Assoc. Prof. PhD. Eng. Dumitru DELEANU (Constanta Maritime University, ROMANIA)

Milen DIMITROV (Black Sea Institute Burgas, BULGARIA)
Senior Lecturer Captain Mahmoud El-Sayed El- BAWAB (Arab Academy for Science Technology and Maritime Transport, Alexandria, EGIPT)
S.I. Iunusova ELMAZ (Odessa National Maritime University, UKRAINA)
Luis G. EVIDENTE (John B. Lacson Colleges Foundation, PHILIPPINES)
GLOVATSKA Svitlana (Odessa National Maritime University, UKRAINA)
Vanyio GRANCIAROV (University “Prof.d-r Assen Zlatarov” Burgas, BULGARIA)
Assoc. Prof. Of Navla Science PhD. Kalin Spasov KALINOV (Nikola Vaptsarov “Naval Academy”, Varna, BULGARIA)
Senior lecturer PhD.Eng. Daniela-Elena JUGANARU (Constanta Maritime University, ROMANIA)
Senior lecturer PhD. Simona GHITA (Constanta Maritime University, ROMANIA)
Vladimir KANEV (Expert WEB Application Software Sofia, BULGARIA)
Assoc.Prof. Dr Momoko KITADA, PhD, MSc/Dip. (World Maritime University, Malmö, SWEDEN)
Tatiana KOVTUN (Odessa National Maritime University, UKRAINA)
Teresa J. LEO (Universidad Politecnica de Madrid /SPAIN)
Valeriu LUNGU (Moldova Technical University)
Assoc. Prof. PhD. Marusya LUBCHEVA (Black Sea Institute Burgas, BULGARIA)
Lyubcho LYUBCHEV, Ph.D. (University “Prof.d-r Assen Zlatarov” Burgas, BULGARIA)
Prof. Irena MARKOVSKA, Ph.D. (University “Prof.d-r Assen Zlatarov” Burgas, BULGARIA)
Francesc Xavier MARTINEZ DE OSES (Departament de Ciencia i EnginyeriaNautiques/Universitat Politecnica de Catalunya/SPAIN)
Magdalena MITKOVA (University Prof.d-r Assen Zlatarov” Burgas, BULGARIA)
Assist Prof. Walter K. NADONY (Marine Transportaton and Environmental Management – State University of New York Maritime College, Bronx, New York, (UNITED STATES of AMERICA)
Asist.Dr. Sabina NEDKOVA (University ‘Prof.d-r Assen Zlatarov” Burgas, BULGARIA)
Assoc. Prof. PhD. Nataliya Danailova NIKOLOVA (“Nikola Vaptsarov “Naval Academy, Varna, BULGARIA)
Assist.PhD. Stoianka Georgieva Tania PETKOVA (“Prof.d-r Assen Zlatarov University, Burgas, BULGARIA)
Assoc. Prof. PhD.Eng. Alexandra RAICU (Constanta Maritime University, ROMANIA)
Assoc. Prof. PhD. Gabriel RAICU (Constanta Maritime University, ROMANIA)
Evghenyi RUDENKO (Odessa National Maritime University, UKRAINA)
Assoc. Prof. PhD.Eng. Liviu-Constantin STAN (Constanta Maritime University, ROMANIA)
Lecturer Capt Emre UCAN (Dokuz Eylul University, TURCIA)

Editorial Secretary

Assist. Alexandru-Andrei SCUPI, Ph.D. (Constanta Maritime University/ROMANIA)
Assist. Iulia-Alina ANTON (Constanta Maritime University/ROMANIA)
Assist. PhD. Eng. Ionut VOICU (Constanta Maritime University/ROMANIA)

Computerized redaction

TOMA Anisoara (Constanta Maritime University/ROMANIA)

Web Administrator

POPESCU George

JOURNAL ADDRESS

Journal of Marine Technology and Environment

Constanta Maritime University, 104, Mircea cel Batran Street, 900663, Constanta, Romania
Tel: +40 241 664 740/ 107
Fax: +40 241 617 260
E-mail: jmte@cmu.edu
<http://cmu-edu.eu/jmte/>

EDITURA NAUTICA

Constanta Maritime University
**CONSTANTA MARITIME UNIVERSITY, 104, MIRCEA CEL BATRAN STREET, 900663,
CONSTANTA, ROMANIA**

CONTENTS

SWOT ANALYSIS OF THE PHILIPPINE MANNING	
1.	¹ BAYLON M.ANGELICA, ² VAdm EDUARDO Ma R SANTOS, AFP (RET) ^{1,2} Maritime Academy of Asia and the Pacific, Mariveles Bataan, Philippines..... 5
ISSUES IN THE HANDLING OF A MULTI-MASTED SAILING VESSEL IN VARIOUS HYDRO-METEOROLOGICAL CONDITIONS	
2.	¹ DACHEV YURIY, ² LAZAROV IVO ^{1,2} Nikola Vaptsarov Naval Academy, Varna, Bulgaria..... 29
R SCRIPTING LIBRARIES FOR COMPARATIVE ANALYSIS OF THE CORRELATION METHODS TO IDENTIFY FACTORS AFFECTING MARIANA TRENCH FORMATION	
3.	LEMENKOVA POLINA Ocean University of China, College of Marine Geoscience, Qingdao, China..... 35
ENVIRONMENTAL IMPACT OF POLUTANTS ON SOIL AND SUBSOIL	
4.	¹ PANAITESCU MARIANA, ² PANAITESCU FANEL-VIOREL ^{1,2} Constanta Maritime University, Engineering Sciences in Mechanics and Environment Field Department, Constanta, Romania..... 45
MARINE CASUALTY ANALYSIS OF BUNKER TANKERS BETWEEN 1966 AND 2017	
5.	¹ SEVGILI COSKAN, ² YUSUF ZORBA ^{1,2} Dokuz Eylül University, Maritime Faculty, Tinaztepe Campus Buca, Izmir, Turkey..... 51
ADVANTAGES AND DISADVANTAGES OF DIFFERENT TYPES OF MODERN MARINE PROPULSIONS	
6.	VASILESCU MIHAIL – VLAD Constanta Maritime University, Faculty of Naval Electro-Mechanics, Constanta, Romania..... 57

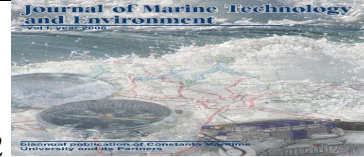

SWOT ANALYSIS OF THE PHILIPPINE MANNING

Prof. PhD. Angelica M Baylon, Ph.D. and VAdm Eduardo Ma R Santos, AFP (Ret)

^{1,2}Maritime Academy of Asia and the Pacific, Mariveles Bataan, PHILIPPINES

Abstract: The Manning industry known as the recruiter and selector of Filipino seafarers to foreign ship-owners for the purpose of manning their oceangoing commercial vessels is on the crossroads in ensuring that the Philippines known as the manning capital of the world would sustain the market leadership of the Philippines in the global ship-crewing industry by constructively addressing a complex of internal issues that threaten competitiveness. While such is a perfectly legitimate aspiration, the larger goal must equally pay attention to the enormous pressures imposed by the external environment, mainly the matter of competition and non-traditional opportunities which emerge within the manning sector, including its direct links with the global maritime industry in which it thrives. The seafarers, predominantly men in the deck and engine positions but joined by a significant number of women in cruise ships, are deployed through the manning companies which select, hire and train them by virtue of contracts with the overseas operators or owners. Filipino seafarers are widely acknowledged by foreign ship-owners, called principals, for their ability to sail and operate merchant ships of all types with efficiency, safety, and general cost-effectiveness. This paper presents an analysis of the strengths, weaknesses, opportunities, and threats that are facing the Philippine Manning Industry for the year 2014-2015.

Key words): Market, analysis, leadership, seafarers, women, opportunities, competitiveness.

1. INTRODUCTION

Shipping is a large global industry based upon a derived demand which is driven by macro issues such as global economic development, structural changes within this, and social trends. When growth slows, the shipping industry cools. When Philippines eat more rice, shipping carries more grain. When the price of oil rises, ships reduce speed to reduce fuel consumption (at the expense of productivity). Thus, as the shipping tasks rises due to economic growth and structural changes, the number of seafarers also rises. Such external drivers form the macro environment that seafaring operates within, and must adapt to as the world evolves. Within the industry itself, structural trends will influence the number of seafarers required (Fisher Report 2013). Of the seafarers plying international waters, over 25% are Filipinos serving as stewards, ratings, and officers, naming the Philippines as the manning capital of the world. This leadership did not happen overnight, it has been the continued efforts of old seafarers and leaders that ensured that Filipinos become the 'seafarers of choice' in the maritime world. Over the years, it is with this position that country has been challenged on all sides especially with respect to its capacity and commitment to supplying competent officers and skilled

ratings in accordance to the requirements of the International Convention on the Standards of Training, Certification, and Watchkeeping (STCW) 2010. While Filipino seafarers may still be considered as 'seafarers of choice' by various international shipping companies' because of their training, skills, and experience, their competitive advantages will have to be strengthened by maintaining and improving the systems and standards of the country's maritime educational and training institutions. Baylon (2002) studied the Manning Industry Behaviour and Its impact on the Philippine economic development using data generated from 1996 to 2002. Although the Philippines had maintained its stand as the manning capital of the world, there was an observed downtrend in the deployment of Filipino seafarers. Five major reasons were noted by the respondents (government agencies, manning agencies and active seafarers on vacation) namely: *maritime administration/political system; competitive wage threats to Eastern European countries and Asian neighbors; decline in maritime education and training; Legal cases/absurd court litigations and; certification system especially in the proliferation of fake certificates. The Philippines as a seafarer supplying nation was threatened by other nationalities accepting lower wage with reason that boils down to economics or global*



recession. Likewise, the proliferation of fake training and competency certificates discovered to be coming from the Philippines, had banned thousands of Filipino seafarers from boarding any vessels carrying the Norwegian flag in January 2002 thus putting the Filipino seafarers at risk in losing their jobs. While the Philippine government was strict, some unscrupulous manning agencies and seafarers were not, which if the manning industry is stuck with it, would eventually affect the Philippine economic development. Baylon (2002) recommended for a need to streamline the maritime administration in the country thru a creation of a single integrated maritime administration to muster all the huge maritime business. Unlike other nations who have gone economically ahead of Philippines, the maritime sector can maximize its benefits truly from the bounties of the sea and shipping businesses. Similarly, in the NRCP-funded research project of Baylon (2011) on “Challenges of the Philippine Maritime and Education” from the maritime stakeholders’ viewpoints, the clamor of the maritime stakeholders for a single maritime administration to be responsible for many other maritime issues raised in support to EMSA audit findings was noted. Maritime stakeholders are joining hands so that Maritime Education and Training (MET) would be supplemented by more onboard training, more of practice-oriented and enhanced by current technologies and simulators with competency to be assessed against the industry's standards. Thru RA 10635, a single maritime administration has been finally signed on April 30, 2012 with MARINA responsible for the STCW implementation beneficial for the seafarers. As the manning industry is revolving the present study provides an update of its Manning Industry status from 1996-2002 to 2014-2015 with a SWOT analysis

2. METHODOLOGY

This study employs a descriptive analysis of data to explore and explain the present status of the manning industry and its contribution to the shipping industry in particular. This study involves both qualitative and quantitative analysis of primary and secondary data which include mostly the knowledge and insights of experts from industry— seafarers and/or maritime leaders. Information was obtained from official government websites, interviews and survey of experts, transcription, and documentation of conferences, fora, roundtable discussions and other meetings. Further, this study involves foresight methods to assess future conditions based on current conditions and trends. Foresight is a process by which one comes to a fuller understanding of the forces shaping the long-term future which should be taken into account in policy formulation, planning and decision making. This involves qualitative and quantitative means for

monitoring clues and indicators of evolving trends and developments and is best and most useful when directly linked to the analysis of policy implications (Martin & Arvin, 1989 as cited by Mohd, et. al. (2012). This study is limited to the use of expert opinion as a foresight method especially in coming up with a SWOT analysis of the manning industry particularly on issues on graduates. Action plans and communications were communicated to concerned institutions and individuals especially maritime experts. Focus group discussions and exploratory meetings were conducted in partnership with maritime organizations such as the Maritime Forum, Association of Global Maritime Education and Training Institutions (GlobalMET), Gydnia Maritime University in Poland, Maritime Labor Convention (MLC) Stakeholders meeting in Berlin Germany and the Nautical Institute. A command seminar was conducted to explore wide range of issues and concerns on navigational Competencies in partnership with Nautical Institute based in London, Associated Marine Officers and Seamen’s Union of the Philippines (AMOSUP) and Masters and Mates Association of the Philippines (MMAP). In conducting the SWOT Analysis of the Philippine Manning Industry, the researcher is guided by the “Project Management Pocketbook” by Posner & Applegarth (2000). The strengths/weaknesses pertain to the internal conditions such as people management expertise, facilities, building, equipment, technology, marketing/sales development skills, reputation/image and financial resources. On the other hand, opportunities/threats deals with external factors such as political/social/economic changes, competition, locally or even nationally, market size and trends, profitability of market, needs that the products fulfill and likelihood of these needs changing. Likewise, the researcher utilized the “Small Business Quick Guide to Understanding a SWOT Analysis” by Mark Laing (2013) as well as the “European Maritime and Fisheries Fund (EMFF) 2014-2020 United Kingdom SWOT and Needs Assessment Analysis” by Slaski, et.al. (2013). Further, the researcher, who actually co-organized/participated, had noted and analyzed the vital information gathered in the following 12 events:

1. WIMAPHIL-MARINA Joint Round Table Discussions with theme “Leveling the Playing field: Challenges to Women Seafarers” held in the Maritime Industry Authority (MARINA) on March 18, 2014
2. 2014 Philippine Seafarers Convention held at the National Library on April 30, 2014 and 2012 Philippine Seafarers Convention held in MARINA, Manila on 25-26 June 2012
3. TKF Foundation Global MET Seminar-Workshop with the theme “Identifying, analyzing and bridging the gap between the STCW Code (1978) as amended and the

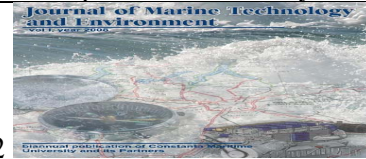

- current course delivery for the marine qualifications” hosted and co-sponsored by MAAP in Manila Yacht Club and MAAP-CAMS in Bataan on April 28-May 2, 2014
4. Preventing Collision and Bridge Watchkeeping Seminar-Workshop held in MMAP House, Malate, Manila on May 23,2014
 5. CRC-UAP Round Table Discussions with theme “*Strengthening Maritime Education: Issues and Strategies: A Round Table Discussion on Maritime Education*” held in the Center for Research and Communication (CRC), University of Asia and the Pacific (UAP) on June 18,2014
 6. Nautical Institute Philippine Branch Exploratory Meeting held in Manila Yacht Club, Manila on July 10,2014
 7. Meeting on K to 12 Project at Incheon National Maritime High School, Incheon, South Korea, October 18-20, 2014
 8. TKF-Global MET Final Phase Seminar-Workshop chaired by MAAP President and Global MET Vice-Chair VAdm Santos, held in Manila Yacht Club on November 24-25, 2014
 9. The Asia Pacific Manning and Training Conference held in Sofitel Hotel, Manila on November 26-27, 2014
 10. Nautical Institute Command Seminar with theme “*Addressing Curriculum and Training Issues on Navigational Competence for Shipping Productivity Gain Cycle*” chaired by MAAP President VAdm Santos held in Davao Room, Sofitel Hotel Manila on November 28, 2014
 11. TRANSSNAV International Conference, Gdynia Maritime University, in Gdynia Poland on June 19-21, 2015
 12. Maritime Labor Convention Stakeholders Meeting in Berlin Germany on June 26-28, 2015.

3. RESULTS AND FINDINGS

This SWOT Analysis is focused on the quality and quantity of Filipino seafarers and all other issues revolving around them to ensure their international competitiveness

3.1 Analysis of Strengths

Strength # 1 International recognition as the manning capital of the world

According to POEA, the Philippines is the world's leading supplier of seafarers since 1987 and is the manning capital of the world. Filipino seafarers account for more than 25% of the world's seafarers. The

International Chamber of Shipping (ICS) reported over 50,000 merchant ships registered in over 150 nations and manned by over a million seafarers of virtually every nationality. The Philippines and India are very significant maritime labor supply nations, with many seafarers from these countries enjoying employment opportunities on foreign flag ships operated by international shipping companies (ICS, 2015). Also, in the Deloitte survey of companies and practitioners, it was reported that Philippines and India supply more officers to the world fleet than any other country. Explicitly, the report stated that only the Philippines remains the largest market for crewing, advantaged by the fact that these people communicate very well in English. The maritime profession is desirable in the Philippines due to numerous factors including the country's geographical position consisting of approximately 7,100 islands, high unemployment rate, and population growth rate.

Strength # 2 High Rate of Deployment

Over the years, there has been a consistent growth in the number of Overseas Filipino Workers (OFWs), supported by increasing globalization and Filipino workers preference for the job abroad because of higher wages and better employment opportunities. Data in **Figure 1** shows that the number of Workers with the Number of Workers with Contracts Processed grew by a compounded average of 7.3% from 2008 – 2013. Of the total contracts processed, the number of land-based workers and sea-based workers increased by an average of 9.9% and .33%, respectively. It may be noted, however, that the share of the sea-based workers' contracts has generally been declining, from 31.33% in 2008 to 21.76% in 2013.

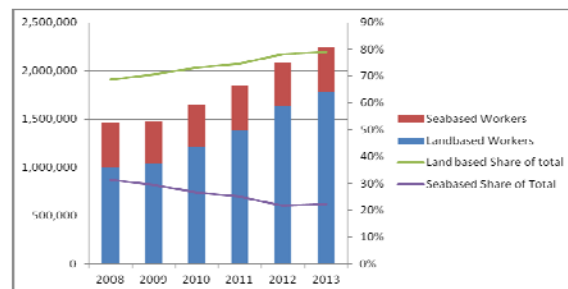

Source: Philippine Overseas Employment Administration

Figure 1 Number of Workers with Contracts Processed by Type: 2008 – 2012

On the other hand, as illustrated in Figure 2, deployment of OFWs grew at an average of 6.8% from 2008–2013 with land-based and sea-based deployment increasing annually by 6.7 % and 5.8%, respectively.

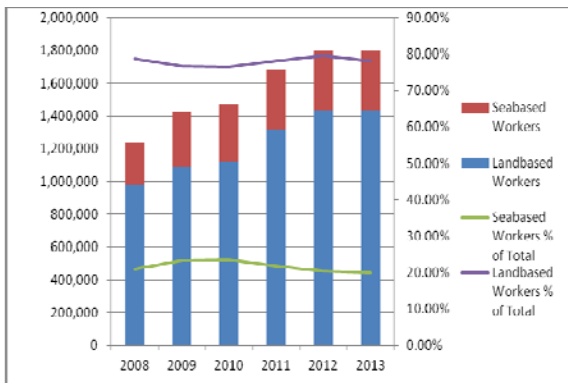
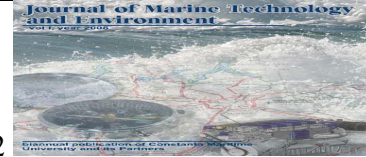

Source: Philippine Overseas Employment Administration

Figure 2 Number of Deployed Overseas Workers by Type: 2008 - 2012

Data in Figure 3 shows the deployment rate of 78.4% for sea-based workers and 81% for land-based workers in 2013, signaling discrepancies between the contract processing and actual deployment. Of the total

workers deployed, about 20% are sea-based, this share declined from 21.17% in 2008 to 19.99% as of 2013.

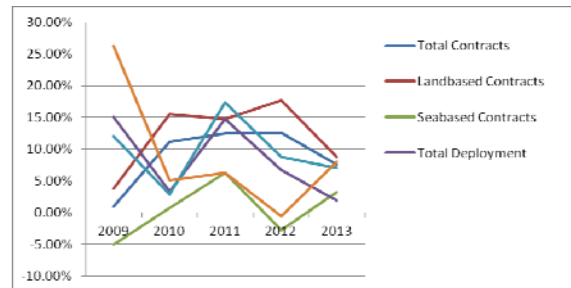

Source: Philippine Overseas Employment Administration

Figure 3 OFW Contracts Processed and Deployment Growth, 2008 - 2013

Deployment of Seafarers

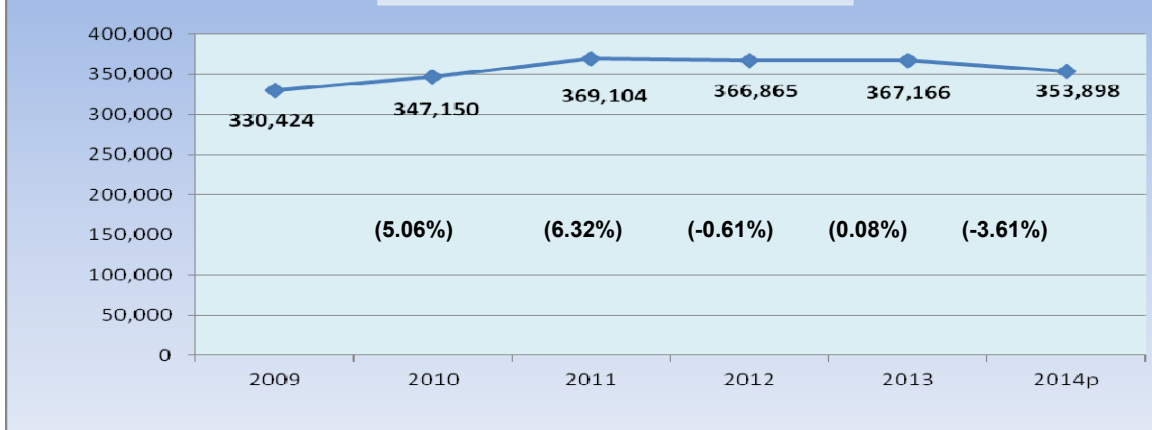

Note: 2014 data are preliminarily obtained from the PSA Report

Figure 4 POEA Data on Deployment of Seafarers (2009-2014)

As of 2013, as shown in **Table 2**, most of the seafarers are deployed in Panama (18.87%), Bahamas

(11.34%), Liberia 9.69%), Marshall Islands (7.47%), and Singapore (5.13%) flag registry respectively.



Table 2: Number of Deployed Seafarers by Top Ten Flags of Registry 2009 – 2013

Flags of registry	2009	2010	2011	2012	2013
	330,424	347,150	369,104	366,865	367,166
Panama	67,361	66,523	72,614	67,567	69,297
Bahamas	36,054	41,814	42,363	38,942	41,627
Liberia	29,796	32,561	39,260	36,912	35,585
Marshall Islands	18,068	21,824	24,235	25,795	27,444
Singapore	15,674	16,417	17,401	19,488	18,820
Malta	14,786	16,971	17,116	17,662	19,249
Bermuda	7,620	9,562	12,830	12,621	15,203
Italy	8,486	11,927	12,822	11,564	11,865
Cyprus					9,517
Greece					8,585
Norway	11,447	12,136	14,187	11,916	4,901
Netherlands	9,281	9,602	10,198	10,644	7,921
Other Flags of Registry	111851	107813	106078	113,754	97,152

Source: Philippine Overseas Employment Administration

Table 3 shows that majority of the seafarers are in non-officers positions, with being an Able Seaman remaining to be the top occupation as of 2013.

However, there has been an increase in the number of officers, growing by 3% annually from 2009 to 2013, to represent about 24% of the total seafarers as of 2013.

Table 3: Deployment of Seafarers By Category or Type (2009-2013)

Deployment of Seafarers	2009	2010	2011	2012	2013
Total	330,424	347,150	369,104	366,865	367,166
Officer	78,893	81,761	90,506	84,836	86,636
Rating	92,027	124,765	140,681	136,505	139,211
Non-Marine	158,808	133,082	136,971	129,822	132,396
Others	696	7,542	946	15,702	8,923

Source: POEA Statistics

Ratings are more numerous, comprising about 38% of the seafarers in 2013. More rating officers are employed as traditionally; the distribution of workers is composed of about 65% rating officers and 35% officers. However, even if there is a massive demand for rating workers, there is currently an oversupply of rating seafarers in the Philippines, as other countries are also supplying this category. At the same time, officer positions require long-term investments from the workers, in terms of time and education, due to higher

licensure and training requirements. Still, Borromeo (2012) stated that Filipinos remain to be the preferred seafarers for many reasons such as their courage, commitment, attitude, values and service orientation, the can do promise and the perpetual smile. From 2009 to 2013, most of the seafarers are aboard bulk carriers (20%), Passenger vessels (19%), and Container vessels (13%), on the average as shown in **Table 4**.

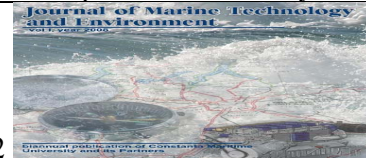

Table 4: Deployment of Seafarers by Top Ten Vessels or Ships Type

	2009	2010	2011	2012	2013
Total	330,424	347,150	369,104	366,865	367,166
1. Bulk Carrier	62,229	67,247	79,381	75,745	80,649
2. Passenger	61,705	69,298	65,510	66,704	68,863
3. Container	44,276	44,691	47,851	46,831	47,251
4. Tanker	30,459	28,065	29,385	24,977	22,808
5. Oil/Product Tanker	22,366	23,319	26,018	23,055	22,203
6. Chemical Tanker	17,179	19,617	21,475	19,498	19,436
7. General Cargo	14,695	14,740	18,660	15,852	16,884
8. Tugboat	10,347	10,396	8,823	10,580	10,456
9. Pure Car Carrier	7,918	9,091	11,555	9,532	9,772
10. Supply Vessel	5,926	6,559	7,458	7,919	9,739
11. Other Vessel Types	53,324	54,127	52,988	66,172	59,105

Source: POEA Statistics

Strength # 3. Increase in the Number of Principals

In 2015, there are 403 POEA registered manning agencies actively engaged in the deployment of seafarers in ocean-going vessels worldwide. This is 15% increase in the number recorded in 2002. Manning agencies were able to seal contracts with foreign principals. **Table 5** shows the number of accredited/registered Sea-based Principals. In 2011, there was 36.20% increase in the number of registered/certified manning principals from 1,112 in 2010 to 1,515. This resulted in the rise of the number of deployed seafarers from 347,150 to 369,104. Consequently, the number of newly enrolled vessels rose by 4.48%, from 2,496 in 2010 to 2,608 in 2011. (POEA Annual Report 2011).

Table 5: Number of Accredited/Registered Sea-based Principals

Year	No. of Principals
2010	1,112
2011	1,515

Strength # 4. High Remittance Contribution of Seafarers

Seafarers are a significant contributor to the Philippine economy. In 2001, their contribution reached \$1.093 billion representing 18.13% of the total remittances of OFWs for that year. This increased with an average annual rate of 15% from 2001 to 2010. Though for the past five years, the yearly growth is down to 10%. In 2013, seafarers contributed as much as \$5.525 billion, representing 22.71% of total remittances for the year. In 2014, BSP reported a total seafarers' remittance contribution of US\$5.576 billion accounting to 22.90% of the total overseas payments. This amount is a 281% increase from the value in 2004, that is, ten years ago. It can be noted that while the number of deployed seafarers declined by 3.6% in 2014, their remittances increased by 6.91%. See **Figure 5** for details.

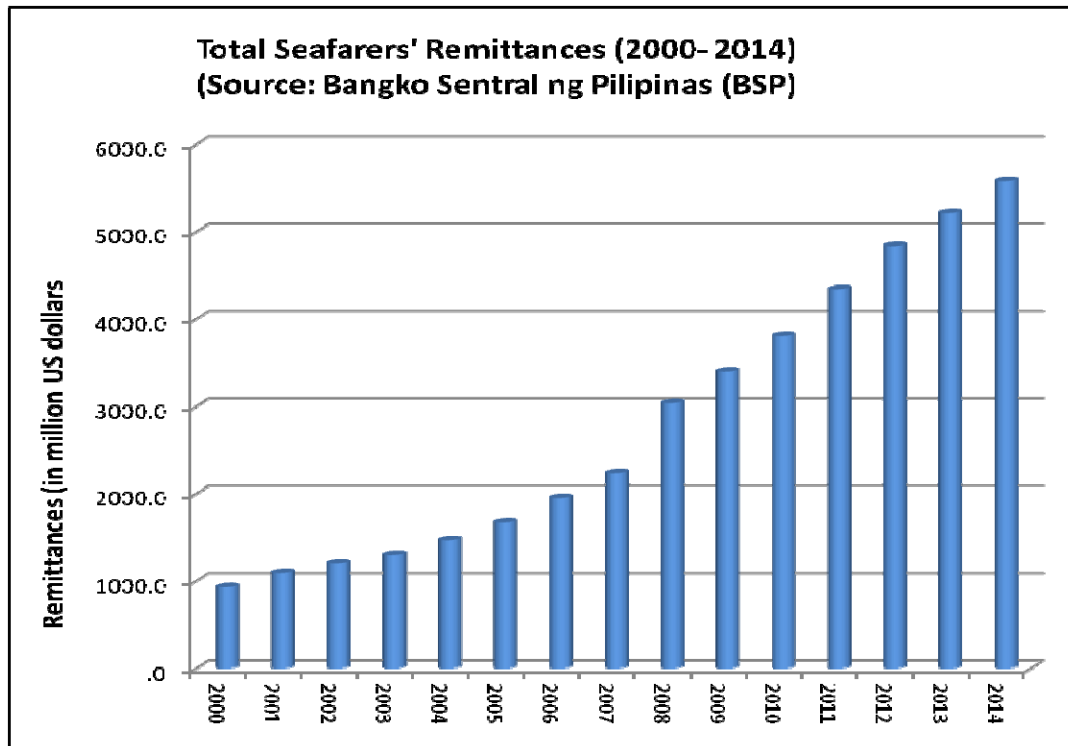

Figure 5 Remittance Contribution of Seafarers (2000-2014)

Regarding gross domestic product (GDP), seafarers' remittances represent about 1.91% of the country's GDP as of 2013. See **Table 6**.

Table 6: Remittances as % of GDP, 2008 – 2013

	2007	2008	2009	2010	2011	2012	2013
Total Remittances	10.9	10.7	10.9	10.7	10.3	8.5	8.4
Sea-based	1.687	1.977	2.136	2.170	2.222	1.921	1.907
Land-based	9.213	8.723	8.763	8.529	8.078	6.579	6.492

Source: Bangko Sentral ng Pilipinas (BSP)

Strength # 5. Increase in the number of maritime enrollees and graduates

From the CHED data, there is a generally increasing number of enrollees in maritime programs as shown in **Figure 6 and Table 7**, respectively. It must be noted that this data covers pre-baccalaureate to maritime doctoral programs. The highest increase (30%) was observed in AY 2009-2010, with 88,567 enrollees from

68,115 in AY2008-2009. Also, a 26% increase was noted in AY2010-2011; then a 21% increase was observed in AY2012-2013. In AY2013-2014, the total enrollees rose to 156,794, which is a three percent (3%) increase from 152,657 in AY2012-2013. The enrollment in AY2013-2014 is a 96% increase from AY2003-2004.

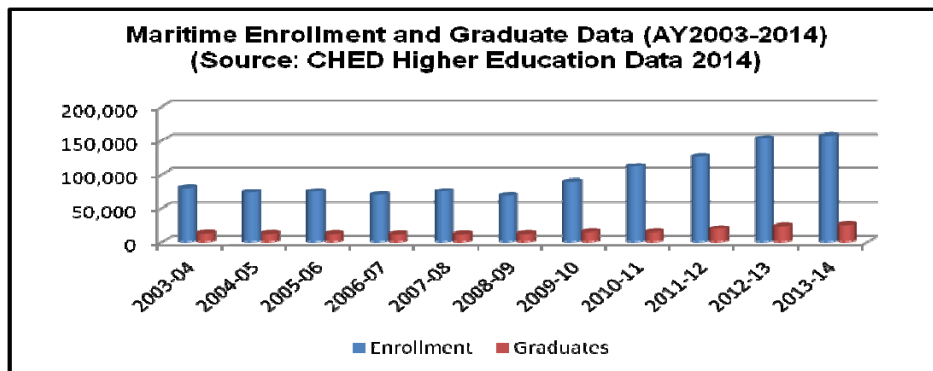
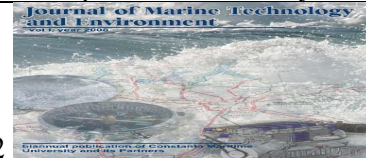

Note: Figures include pre-baccalaureate to doctoral programs

Figures 6 CHED Data on Maritime Enrollment and Graduates (2003-2014)

Table 7 :Number of Enrollees and Graduates in Maritime Program (2003-2014)

Academic Year	No. of Enrollees	% Increase/Decrease	No. of Graduates	% Increase/Decrease
2003-04	79,843		12,487	
2004-05	73,250	-8.26%	12,011	-3.81%
2005-06	74,585	1.82%	11,725	-2.38%
2006-07	69,536	-6.77%	11,360	-3.11%
2007-08	74,853	7.65%	11,352	-0.07%
2008-09	68,115	-9.00%	11,716	3.21%
2009-10	88,567	30.03%	14,439	23.24%
2010-11	111,469	25.86%	14,430	-0.06%
2011-12	125,905	12.95%	19,515	35.24%
2012-13	152,657	21.25%	23,506	20.45%
2013-14	156,794	2.71%	25,309	7.67%

Source: CHED Higher Education Data 2014

Note: Figures include pre-baccalaureate to doctoral programs

Concerning the number of graduates, an average of two percent (2%) decrease is observed from 2004 to 2008. However, the number picked up a little bit with a three percent (3%) increase in AY2008-2009 having 11,716 graduates from 11,352 in AY2007-2008. An increase of 23% was shown in AY2009-2010 while a decrease of less than one percent was noted in AY2010-2011. Positively, 35% increase in maritime graduates is seen in AY2011-2012, 20% in AY2012-2013, and eight percent (8%) in AY2013-2014 with 23,506 graduates. From AY2009-2010 to AY2013-2014, the country has an average of 127,078 annual enrollees and an average of 19,440 graduates in the maritime program from pre-baccalaureate to doctorate.

The increase in the number of maritime enrollees

and graduates is relevant as this is one of the government's priority courses geared towards global employment. While the CHED data provides information on the status of maritime graduates, the data integration from all maritime programs limits the information on the specific graduates of Bachelor of Science in Marine Transportation (BSMT) and Bachelor of Science in Marine Engineering (BSMarE).

Strength # 6. Large workforce pool of ratings and officers

Regarding the total number of licensed seafarers, the Philippine Regulatory Commission (PRC) registered an annual average of 59,739 deck officers and 60,139 engine officers from 2007 to 2011. It can be observed from Figure 7 that majority of the deck and engine officers have an OIC license.

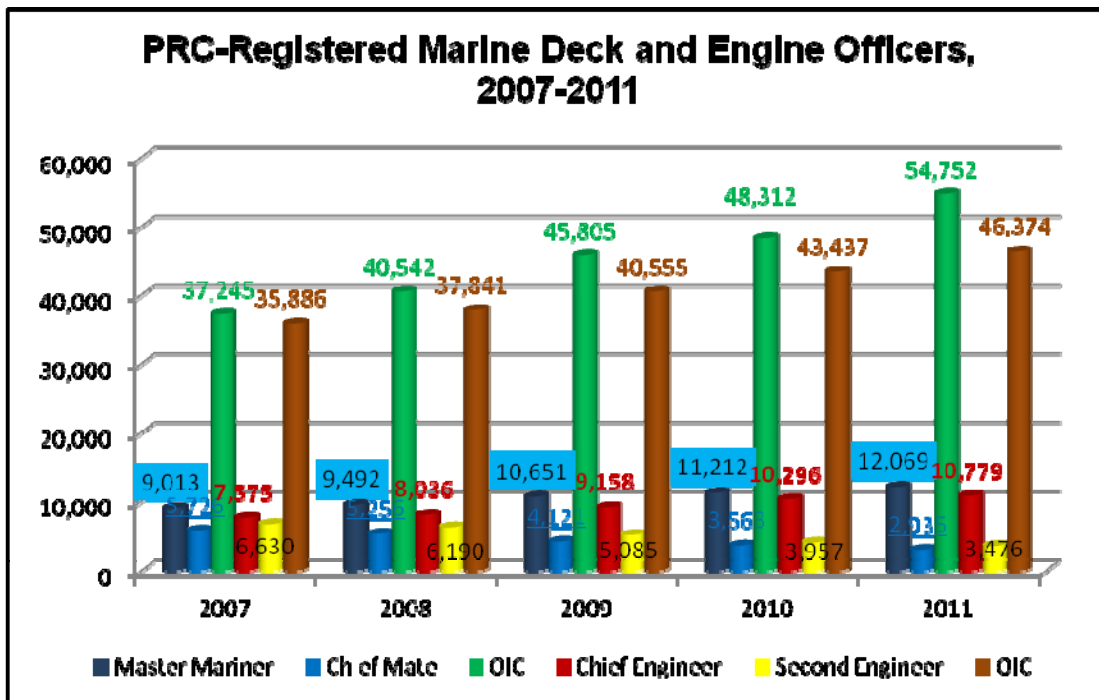
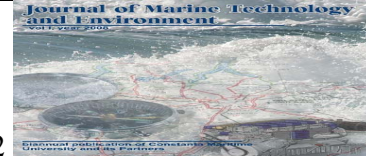

Source: POEA Presentation of Dir. Nini Lanto during the Philippine Seafarers Forum 2012

Figure 7 Numbers of PRC-Registered Deck and Engine Officers, 2007-2011

On the average, 76% of the deck officers are holders of OIC license while 68% of the engine officers are OIC-licensed, as well. At any given year, 17.56% of deck officers are master mariners, and 15.25% of the engine officers are Chief Engineers. For the increase in the number of officers thru the years, it can be noted that there is an average increase of 6.87% on the number of deck officers and 7.66% on the number of engine officers. Both deck and engine OIC-license holders are increasing with an average of 10.16% and 6.62%, respectively. More importantly, the number of master mariners is expanding with an average of 7.61% and the number of chief engineers with an average

increase of 9.29%. The decrease in the number of chief mates and second engineers are observed as they may be upgrading their licenses. In 2014, MARINA issued a total of 978,857 Seafarer’s Identification and Record Book (SIRBs) and Certificate of Proficiency (COP), an increase of 396.65% compared to the number in 2013. This increase is due to the assumption of this function of issuing COP by MARINA under RA 10635. As displayed in **Figure 8**, MARINA published a total of 144,891 SIRBs in 2010, but 1.69% decreases this in 2011 with 142, 449. The number of SIRBs issued increased by 21.73% in 2012 and 13.66% in 2013. (MARINA Accomplishment Reports 2010 to 2014)

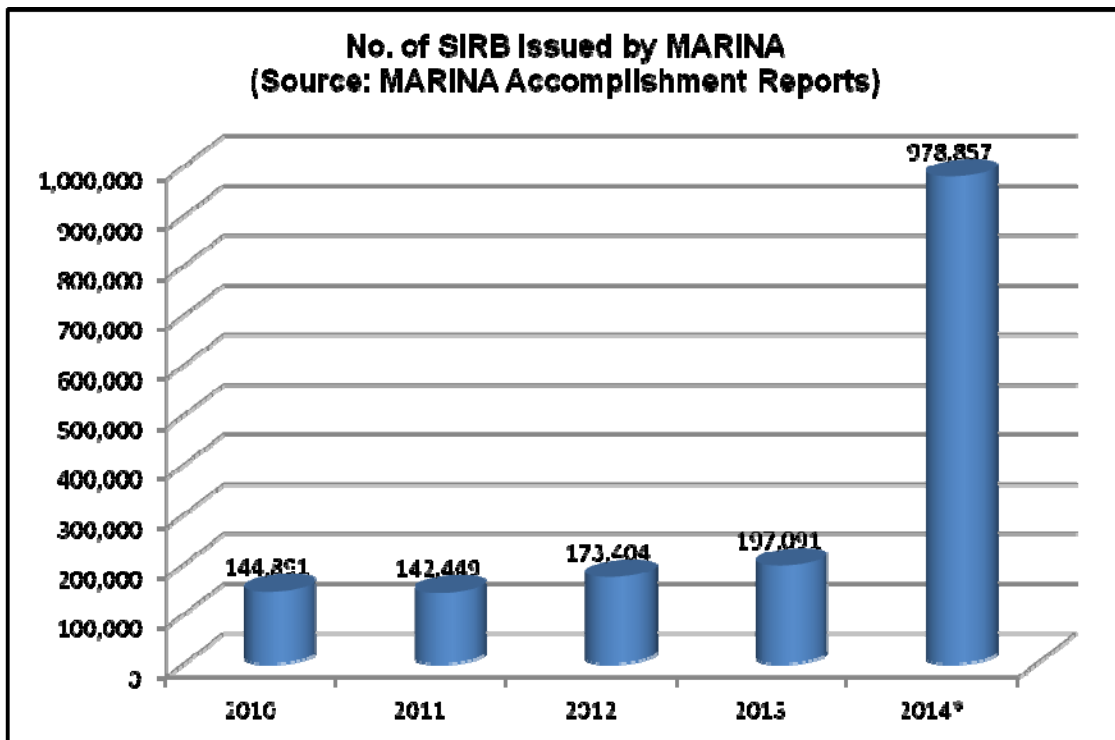
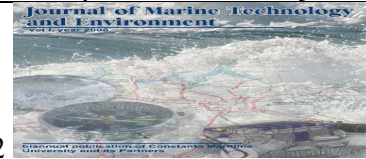

* - SIRB and COP combined

Figure 8 Number of SIRB Issued by MARINA, 2010-2014

Strength # 7. Availability of Welfare Services for Seafarers

With the Philippine ratification of the Maritime Labour Convention (MLC) 2006, otherwise known as Seafarers Bill of Rights, decent working and living conditions for all seafarers must be ensured for seafarers manning ships in international and domestic routes. MLC 2006 provides minimum requirements for seafarers to work on board a vessel; conditions of employment; accommodation, recreational facilities, food and catering; and health protection, medical care, welfare

and social security protection. On top of these, seafarers are provided with welfare services by the government, employers, and seafarers' organizations. The government agencies include the Overseas Workers' Welfare Agency (OWWA), Employers' Compensation Commission (ECC), National Labor Relations Commission (NLRC), Social Security System (SSS), Philippine Health Insurance Corporation (PhilHealth), and Home Development Mutual Fund (HDMF). These are outlined in **Table 8**.

Table 8: The Welfare Services for Seafarers

Agency	Welfare Services
Government	
OWWA	1. Seafarers' Comprehensive Education and Training Program 1.1 Upgrading Program 1.2 Mariners' Dugtong Aral (MDA) 1.3 Incentive Program for Top 200 Maritime Cadets (Cadetship Program) 1.4 Maritime Educational Development Loan Program (MEDLOP) 2. Reintegration Program 3. Medical/Healthcare, Disability and Death Benefits
ECC	1. Employees' Compensation Program; 2. Rehabilitation Services and 3. Medical/Healthcare, Disability & Death Benefits
NLRC	1. Arbitration and adjudication of cases
SSS	1. Disability Benefit; 2. Death Benefit and 3. Retirement Benefit
PhilHealth	1. Inpatient Benefit Coverage; 2. Outpatient Benefit Coverage and 3. Special Benefit Packages
HDMF	1. Provident (Savings) Benefits Claim; 2. Housing Loan Availment and 3. Housing Programs

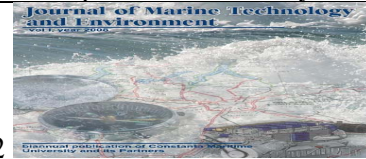

Agency	Welfare Services
Employers (different companies, different benefits)	1. Training, Upgrading of License and Career Progression <ul style="list-style-type: none"> 1.1 training 1.2 training loan schemes 1.3 long-term career development program 2. Health Insurance/Medical Benefits – health cards 3. Financial Assistance/Cooperatives <ul style="list-style-type: none"> 3.1 loans 3.2 cash advances 3.3 cooperatives 4. Monetary Benefits 5. Wives’/Dependents Clubs 6. Board and Lodging
Seafarers’ Associations	1. Legal services; 2. Financial assistance; 3. Medical and dental benefits; 4. Education and training assistance services; 5 Retirement program; 6 Spiritual services; 7. Hostels; 9. Grocery stores and 10. Housing program

Source: Challenges Facing Seafarers’ Welfare: An Analysis of Current Welfare Programs vis-à-vis Seafarers’ Needs - A collaborative research undertaking among the National Maritime Polytechnic (NMP), Overseas Workers Welfare Administration (OWWA) and Associated Marine Officers’ and Seamen’s Union of the Philippines (AMOSUP)

Strength # 8. Improvement/Streamlining in the maritime administration

The Philippines became a party to the STCW Convention of 1978 through an instrument of accession submitted to the International Maritime Organization (IMO) on January 11, 1984. However, it took 30 years and the risk of impending sanctions such as the non-recognition of STCW Certificates issued by the government and further displacement of about 80,000 Filipino seafarers aboard EU-flagged ships, to enact Republic Act (RA) 10635 as a means towards full compliance to the Convention (Congress Watch Report, April 7, 2014). Nonetheless, this legislative act also addressed the findings in the Human Resource Development in the Asia and the Pacific Report that some approaches to the maritime safety administration (MSA) role are not consistent with the perceived best practice model. This includes the Philippines that has a multi-agency situation leading to issues related to control and accountability directly impacting seafarer training. (Fisher Association Ltd., 2013). Before the enactment of Republic Act (RA) 10635, Executive Order No. 75 was issued on April 30, 2012. This EO 75 designates the Department of Transportation and Communications (DOTC), through the Maritime Industry Authority, as the single administration in the Philippines responsible for oversight in the implementation of the 1978 International Convention on Standards of Training, Certification, and Watchkeeping for Seafarers, as amended. RA 10635 is the “An Act Establishing the Maritime Industry Authority (MARINA) as the Single Maritime Administration Responsible for the Implementation and Enforcement of the 1978 International Convention on Standards of Training, Certification and Watchkeeping for Seafarers, as amended and International Agreements or Covenants Related Thereto, otherwise known as the “MARINA STCW

Administration Act of 2014”. According to its mandate, MARINA issued the Implementing Rules and Regulations for this law on July 24, 2014. (MARINA, 2014). Moreover, RA 10635 delegates other relevant tasks to other government agencies such as the Commission on Higher Education (CHED), National Telecommunications Commission (NTC), and Department of Health (DOH). On the other hand, during the Asia-Pacific Manning and Training Conference 2014, the Philippine government has shown that the Maritime Philippines is a strong, cohesive unit with legislative and executive support steadily rising to the occasion. During this international event in Manila, the Executive Branch of government, represented by The Honorable Zeneida Angara-Collinson, the Assistant Secretary for European Affairs of the Department of Foreign Affairs, and by Maritime Industry Authority (MARINA) Administrator Maximo Q. Mejia, Jr, showcased improvements in education and training that the Philippines has made to comply with the STCW convention, and how these further reinforce “Brand Philippines“. Also, the Legislative Branch of government with Senate President Franklin M. Drillon and Congressman Jesulito A. Manalo of the ANGKLA (Maritime Party of the Philippines) reiterated the committed support from the Philippine government for the maritime industry and mentioned the reforms being made by both Legislative and Executive branches of the government.

Strength # 9. Public-Private Partnership in the Maritime Sector

The interests of the stakeholders are very well-represented. This was mentioned on June 17, 2014 at Ermita Manila, in the interview by Ms Teresa Javier with Mr. Alexander Querol of Magsaysay Maritime Corporation, one of the most awarded manning agencies in the country. The different maritime stakeholders recognize the immense contribution of the seafarers in

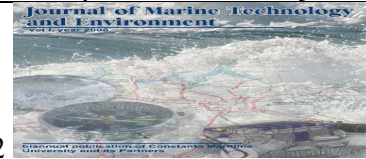

keeping the economy afloat and in return, they do their share. There are unions that speak for the special concerns of workers. In addition, the government endeavors to voice out the issues of seafarers to the international community and look after their rights. The government is also tasked with the regulation of recruitment and deployment, and thus ensured quality of workers through its certification requirements. Manning companies also seek to uphold and implement employment terms and conditions, as well as advise foreign partners to make sure procedures are in accordance with POEA guidelines. They help the government in its advocacy by providing the necessary market condition in terms of employment opportunities. Manning corporations also make sure that allotments to the families are delivered in a fast and time manner, and that assistance is provided to seafarers who need it. Manning agencies also band together to form associations such as Filipino Association for Mariners' Employment, Inc. (FAME) and the Joint Manning Group (KMG), to better lobby for the shipping and manning industries. The Joint Manning Group (JMG), organized on September 17, 2008, is an umbrella organization of independent, well-established and long-standing maritime and manning associations in the country namely: Filipino Association for Mariners' Employment, Inc. (FAME), Filipino Shipowners' Association (FSA), International Maritime Association of the Philippines (INTERMAP), Philippine Association of Manning Agencies and Shipmanagers Inc. (PAMAS), and Philippine-Japan Manning Consultative Council (PJMCC). JMG aims to jointly and continuously push for the development of the Philippine manning and shipping industry. JMG represents the maritime and manning industry that brings in close to US\$5 billion in foreign exchange earnings and provides employment to over 500,000 Filipino seafarers including related trades and businesses. JMG is a catalyst for growth for the industry and for the advancement of the ideals and interest of its membership. (www.jobs-marino-go.com). The Filipino Association for Mariners' Employment, Inc. (FAME) is a recognized organization that aims to: unite all legitimate ship manning companies for a more formidable presence in and source of the world's maritime labor force; promote safety of life and property at sea; and, to protect the marine environment through strict adherence to IMO conventions, including the STCW Convention '78, as amended; consistently ensure the competency of the Filipino seafarers within international standards as its collective response to the challenges of globalization; establish close coordination with the government for reciprocity of assistance in terms of privileges, exemptions or concessions as may be beneficial in compliance with international and statutory requirements; assist in the improvement of the welfare

of seafarers through participation in various government endeavors to further develop and maintain the competitive spirit of the Filipino Seafarers and others which shall include but not limited to the ratification of international conventions; encourage a quality management system among its members; to enhance the reliability and effectiveness of its goods and/or services; instil professionalism among its members through governance and adherence to a Code of Ethics; initiate proposals towards reduction of bureaucratic requirements or red tape of government entities regulating the ship manning industry; enter into any lawful agreement with any foreign national or entity in the furtherance of its objective; and conduct and transact any and all lawful activities; and, to do or cause to be done any or more of the acts set forth in the preceding objectives desirable to the accomplishment of its purposes. (www.fame.org) Other maritime organizations such as Filipino Shipowners' Association (FSA), International Maritime Association of the Philippines (INTERMAP), Philippine Association of Manning Agencies and Shipmanagers Inc. (PAMAS), and Philippine-Japan Manning Consultative Council (PJMCC) equally play important roles in the Philippine Manning Industry. The FSA composed of 31 shipping companies that own, manage, operate and/or charter Philippine flagships for overseas trade, is committed to the development of the Philippine overseas shipping industry. The International INTERMAP is an association of shipping companies engaged in chartering ocean-going vessels registered under the Philippine Flag under MARINA's supervision. It was created to assist and enhance the development and balanced growth of the maritime industry, and establishing global competitiveness of vessels under the Philippine registry. The PAMAS is an association of companies engaged in the business of manning and management of foreign-owned ocean-going vessels and is committed towards the promotion and welfare of our crew-supplying industry. The PJMCC is a non-stock, non-profit organization that focuses on the maritime and seafaring industry both in the Philippines and in Japan, especially those concerning Filipino seafarers' welfare and their training to improve their skills and competencies.

Table 9 lists the maritime organizations in the shipping manpower sector obtained from the website of the Maritime Industry Authority (MARINA). Associations promote the competitiveness of Filipino seafarers by participating in conferences, discussions, and others to enhance and promote employment. Because shipping companies go through agencies to employ workers, the agencies are responsible for promoting and propagating the attractiveness of the Filipino seafarers. On the other hand, financial institutions work with other industry players to provide facility in remittances.



Table 9: List of Maritime Organizations in the Shipping Manpower Sector

Maritime Association	Composition
Associated Philippine Seafarers Union (APSU) (www.psu.org.ph)	Overseas merchant seafarers on board ships trading worldwide.
Association of Marine Officers and Seaman's Union of the Philippines (AMOSUP)(www.amosup.org)	Over 100,000 active members – seafarers on board international vessels
Conference of Maritime Manning Agencies (COMMA)	Manning agencies
Filipino Association for Mariners' Employment, Inc. (FAME) (www.fame.org)	127 members (manning agencies), supplying about 75% of the annual industry's deployment
International Maritime Association of the Philippines (INTERMAP)	shipping companies engaged in chartering ocean-going vessels registered under the Philippine Flag under the MARINA's supervision
Marine Engineers and Officers Association of the Philippines (MEOAP)	licensed marine engineers and officers in the Philippines
Bay Pilot's Partnership	
Masters and Mates Association of the Philippines (MAMAP)	Licensed masters and mates in the Philippines
Philippine Association of Maritime Training Center, Inc. (PAMTCI)	Association of maritime training centers
Philippine Association of Manning Agencies & Shipmanagers, Inc. (PAMAS) (www.pamas.ph)	group of companies engaged in the business of manning and management of foreign-owned ocean-going vessels
Philippine Association of Maritime Institutions (PAMI)(www.pami.org.ph)	Maritime union composed of seafarers on board international vessels
United Filipino Seafarers (UFS) (unitedfilipinoseafarers.com.ph)	Union of seafarers on board vessels
Philippine Ship Agents Association (PSAA) (www.psaa-ph.com)	PSAA has grown from a small group of ship agents to 52 progressive ship agents

Strength # 10. Recognition of quality/excellent manning agencies

Manning agencies play a significant role in the recruitment, selection, and deployment processing of seafarers in the international fleet. In recognition for their outstanding services to the Filipino people, the government has been providing Top Performance Award, Award of Excellence, and Presidential Award of Excellence to deserving land-based and sea-based overseas recruitment agencies on a four-year cycle basis. To qualify for the agency performance awards, licensed agencies must meet three necessary requirements: no record of cancellation or reversal of removal (i.e., a reviewing court considers the decision of a lower court as incorrect and overturns the decision) or suspension of license or documentary suspension for failure to comply with POEA rules; the number of complainants in pending recruitment violation cases should not exceed one percent of total deployed workers; and an agency should have deployed at least 1,000 workers during the period under review. Recruitment agencies are evaluated based on the following criteria: volume and quality of deployment, agency management and recruitment capability, compliance with recruitment rules and regulations, industry leadership and pioneering achievements and contribution to developing overseas employment policies, and social awareness and responsibility. Furthermore, to qualify for the Top Performer Award,

an agency should be in operation for at least four years. The Award of Excellence is given to an agency that has been conferred the Top Performer Award three times. The Presidential Award of Excellence is bestowed to an agency which has been a recipient of the Award of Excellence at least five times. The Malacañang Palace provides Presidential Award of Excellence which was established pursuant to Proclamation No. 1519 dated May 24, 2008, to "recognize the consistent excellent performance of private employment and manning agencies licensed by Department of Labor and Employment (DOLE) through the POEA in providing decent and remunerative employment to Overseas Filipino Workers." According to DOLE Secretary Rosalinda Dimapilis-Baldoz, this award is the highest honor bestowed upon a licensed overseas recruitment agency in a three-tiered reward system for private recruitment agencies that exemplify the highest standards of ethical recruitment and deployment of Filipino workers for overseas employment. The POEA award is one reason that drives manning agencies to excel not only in their business but also in the services, including training, they provide to the seafarer. The government, the seafarer and their families all benefit from the award. In February 2014, As shown in **Table 10**, three (3) sea-based agencies were given Top Performer Award, eight (8) are Awardees of Excellence and ten (10) are awardees of the Presidential Award of Excellence.

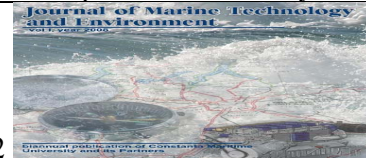
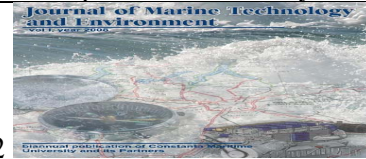

Table 10: POEA-Awarded Sea-based Manning Agencies

Manning Agencies	2002	2005	2009	2014
1. Anglo-Eastern Crew Management Philippines, Inc				
2. Arphaphil Shipping Corp.				
3. Avantgarde Shipping Corp				
4. Bahia Shipping Services Inc				
5. Baliwag Navigation, Inc				
6. Barko International, Inc				
7. Bergesen DY Philippines				
8. Blue Manila Inc				
9. Bright Maritime Corporation				
10. BSM Crew Service Centre Philippines, Inc (formerly Phil. Hammonia Ship Manning Agency)				
11. Career Philippines Shipmanagement, Inc				
12. CF Sharp Crew Management, Inc				
13. Crossworld Marine Services, Inc				
14. CTI Group Phils				
15. Dohle-Philman Manning Agency, Inc				
16. Dolphin Shipmanagement Inc				
17. Hanseatic Shipping Phils Inc				
18. Hoegh Fleet Services Phils Inc				
19. INC Navigation Company Philippines, Inc				
20. Inter-Orient Maritime Enterprises, Inc				
21. Jebsens Maritime, Inc				
22. KGJS Fleet Management Manila				
23. Leonis Navigation Company, Inc				
24. Maersk-Filipinas Crewing, Inc				
25. Magsaysay Maritime Corporation				
26. Magsaysay MOL Marine, Inc (ex Magsaysay Mitsui OSK Marine)				
27. Maritime Services & Management Inc				
28. Marlow Navigation Phils, Inc (ex- Crewserve Inc)				
29. Michaelmar Phils, Inc				
30. MST Marine Services (Phils) Inc				
31. NAESS Shipping Philippines Inc				
32. Netship Management Inc				
33. New Filipino Maritime Agencies, Inc				
34. NFD International Manning Agents Inc				
35. North Sea Marine Services, Inc				
36. NYK-Filship Management, Inc				
37. Orient Ship Management Phils., Inc.				
38. Oriental Shipmanagement Company Inc				
39. Orophil Shipping International Co, Inc				
40. OSM Maritime Services, Inc				
41. Pacific Ocean Manning, Inc				
42. Pacific Seamen Services Inc				
43. Parola Maritime Agency Corp				
44. Philippine Hanse Ship Agency Inc.				
45. Philippine Transmarine Carriers, Inc				
46. Scanmar Maritime Services, Inc				
47. Sealanes Marine Services, Inc.				
48. Sea Power Shipping Enterprises, Inc				
49. Senator Crewing (Manila) Inc				
50. Singa Ship Management Phils Inc				
51. Southfield Agencies Inc				
52. Stolt-Nielsen Philippines, Inc				
53. Swedish Crewing Management, Inc.				
54. Task Agencies, Inc.				
55. Teekay Shipping Phils. Inc				
56. Trans-Global maritime Agency Inc				
57. TSM Shipping (Phils) Inc				
58. United Philippine Lines, Inc				
59. Ventis Maritime Corporation				
60. Veritas Maritime Corporation				
61. Wallem Maritime Services, Inc				

Legend: Presidential Award of Excellence Awardee ■
 Awardees of Excellence ■
 Top Performers ■



Strength # 11. Reforms in MHEIs for better industry workforce entrants

The importance of Filipino labor to the shipping industry and to the national economy places considerable responsibility on the country's maritime education and training infrastructure. Apart from this, there is a growing demand for quality and globally competitive graduates, not only on the maritime field but also in other specializations, brought about by the increasing globalization including the ASEAN integration. With these, the Commission on Higher Education (CHED) has been promoting a paradigm shift to learning competency-based standards in the Philippine higher education to enable graduates to acquire knowledge and skills aligned with the needs of the industry. CHED has also issued policy-standard to enhance quality assurance (QA) in higher education institutions through outcomes-based and typology-based quality assurance. (CMO 46, series of 2012). Further, with the changes in the Philippine maritime administration and the EMSA Audit results since 2006, CHED and MARINA collaborated to enhance maritime education in the country – ensuring that it is aligned with the current STCW requirements. CHED Memorandum Order (CMO) 27 series of 2013 provided rules and procedures for implementing the joint CHED-MARINA monitoring of maritime education programs offered by maritime higher education institutions (MHEIs). MARINA and CHED audited MHEIs based on their compliance with the standard training requirements stipulated in the STCW Convention, as amended. Out of the 95 MHEIs, only 60 were able to make it to MARINA's "Whitelist." As of February 23, 2015, only 23 MHEIs were recognized by MARINA to offer Bachelor of Science in Marine Transportation (BSMT) for the school year 2015-2016. Similarly, 23 MHEIs are identified to provide Bachelor of Science in Marine Engineering (BSMarE). Thirty-six (36) MHEIs eligible to deliver the ratings (deck) program have expressed their interest to offer the Enhanced Support Level Program (ESP-Deck) while 34 MHEIs eligible to provide the ratings (engine) program expressed their interest in giving the ESP-Engine. Others have not yet shown their benefits. On the other hand, 30 MHEIs are still undergoing further review for BSMT while 21 MHEIs for BSMarE. In the second issue of the MARINA News Digest (April 13, 2015), it was reported that the Technical Panel on Maritime Education (TPME) continues its review on the findings submitted by the joint CHED and MARINA audit teams on accredited MHEIs nationwide. The panel will work towards deciding which MHEIs should continue offering maritime degree program and which should opt to provide the non-degree enhancement program ESLP.

Strength # 12. Close monitoring of accredited maritime training centers

With respect to the maritime training side, there are 119 accredited maritime training centers in the Philippines offering various STCW and non-STCW courses to upgrade the knowledge and skills of ratings and officers. Moreover, these training institutions are organized and formed the Philippine Association of Maritime Training Centers, Inc. (PAMTCI) which also represents these institutions in various fora, conferences or meetings in the maritime industry. On the other hand, the MARINA also accredits the instructors and assessors of maritime training institutions pursuant to the Presidential Decree No. 474, Executive Order No. 125/ 125-A, Executive Order No. 75 and its Implementing Rules and Regulations (IRR) and in compliance to the STCW 1978, as amended. (MARINA Circular No. 2013-12 Series of 2013)

4. ANALYSIS OF WEAKNESSES

Weakness #1. Diverse Issues and Concern with new regulations

With the crucial drastic government reforms in compliance to STCW requirements, maritime education and training institutions, manning agencies, and other maritime stakeholders, most especially the seafarers and maritime students are primarily affected and are necessitated adopt to these reforms and advancement in the maritime industry. Issues and concerns on training, regulations and other aspects should be addressed by all concerned. During the Seafarers' Forum, several officers expressed their concerns about having to retake Management Level Courses (MLCs) with the implementation of STCW 2010. More than that, seafarers are clamoring over the full training required of them before they are deployed on board ships. The MARINA representative justified that it is for the best interest of the government to enhance the competencies of the seafarers for them to retain their jobs and for the country to maintain its position as the manning capital of the world. During the Asia-Pacific Manning Conference 2014, Prof. Helen Sampson of the Seafarers International Research Centre (SIRC), based on her research, concluded that seafarers have adjusted well to the new environmental regulations however she did raise some concerns that crew is subjected to additional stress as a result of inadvertent violations, fear of losing one's job, and the increased possibility of extortion, as a result of additional regulations. (Borromeo, 2014)

Weakness # 2. Lack of Government Support for Seafarers' Education

With the implementation of RA 10635, which centralized the Maritime Industry Authority (MARINA) as the single maritime administration, fines and other sanctions are faced by maritime schools and training centers that are not able to comply with the STCW requirements. However, no reward system is in place to support outstanding maritime education and training

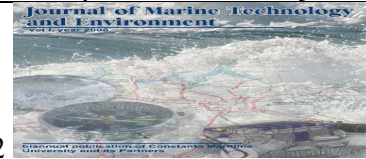

institutions for meeting or exceeding the standards. Moreover, government support for MET infrastructure developments lacks even though maritime transportation is listed as one of the CHED's priority courses of AY2014-2015 to AY2017-2018 (CMO No. 01, series 2014). **Even in the Investment Priority Plan (2013), maritime is not included; although shipping which is a part of the maritime industry is a priority.** It must be noted that quality MET is not only intended for seafarers manning ships on international routes but more so seafarers on domestic shipping lines.

Weakness # 3. Inadequate facilities and equipment in MHEIs

The Philippines has a widespread perception that standard in many maritime colleges are poor. Potential is not being realized but the issues have defied previous attempts to resolve them, resulting in skepticism that this can be done the future. Companies try to take the best candidates (often putting potential recruits through their own exams before employing them), and fill in the gaps in training at colleges supported by them. Subsequent training for higher certificates is typically undertaken at institutions also supported by companies – a significant private sector investment has taken place for such. Also, some approaches to the maritime safety administrations (MSA) role are not consistent with the perceived best practice model. Some such as the Philippines have had a multi-agency situation leading to issues related to control and accountability, which directly impacts on the seafarer training. (Fisher Association Ltd., 2013)

Weakness # 4. Inadequate qualified trainers/trainers in MHEIs

There is shortfall in the quantity and quality of trainers and lack of sustainability of supply of professional trainers due to salary gap between being at sea and being a professional trainer and perception that all trainers must be former mariners. (Fisher, 2013). During the Asia-Pacific Manning and Training Conference 2014, some of the manning and training challenges include the continued shortage of quality officers and the lack of berths; the need for quality faculty, for alignment between education and industry; the sustainability of training systems across the world; and networked training for seafarers. Also, during this event,

Capt Pradeep Chawla highlighted the need for good faculty, and uniform training methodologies, across all countries. (Borromeo, 2014)

Weakness # 5. Gaps/Issues on maritime education output and industry needs

According to the Fisher Report 2014, there is a gap between course structures and curricula in different countries in the Asia and the Pacific. This is very true also with the Philippines, though efforts are being done by the government to improve the maritime curriculum through various technical working groups involving various maritime stakeholders including maritime educators.

Weakness # 6. Lack of berths for cadet training program

While there are excellent programs provided by the industry, most especially by the shipping or sponsoring companies, berth for cadetship training program for aspiring seafarers or officers is lacking. Some companies are reluctant to host cadets on board their ships, or may not have accommodation exacerbated by Maritime Labour Convention requiring seafarers to have own cabins (Fisher Report 2013).

Weakness # 7. The decrease in the number of licensure examination takers

With respect to the PRC licensure examination, BSMT takers of the Officer-In-Charge (OIC) for Navigational Watch have an annual passing rate of 51.44% ranging from 46.80% in 2011 to 57.13% in 2012 as shown in **Table 11**. For the Marine Engineering takers of the OIC for Engineering Watch, they have an annual passing rate of 57.87%, with the lowest percentage of 54.71% in 2011 and highest standard of 63.59% in 2013. While they have a relatively good passing rate compared to the other priority disciplines, the numbers of OIC Navigational Watch test takers are decreasing from 8,123 in 2009 to only 2,571 in 2013. Likewise, 3,548 took the OIC for Engineering Watch in 2009 while only 780 in 2013. Thus, even with the increase in the passing rate, there is still decrease in the number of passers. These are despite the rise in the number of graduates earlier reported in **Table 7**. To summarize, from 2009 to 2013, there are 12,603 OIC Navigational Watch passers and 6,705 OIC Engineering Watch passers or license holders.

Table 11: PRC National Passing Percentage for Maritime Licensure Examinations

Year	Marine Transportation (O.I.C. for Navigational Watch)			Marine Engineering (O.I.C for Engineering Watch)		
	Takers	Passers	%	Takers	Passers	%
2009	8,123	3,945	48.57	3,548	1,945	54.82
2010	6,678	3,302	49.45	3,666	2,019	55.07
2011	3,314	1,551	46.80	2,398	1,312	54.71
2012	4,175	2,385	57.13	1,526	933	61.14



2013	2,571	1,420	55.23	780	496	63.59
Total	24,861	12,603		11,918	6,705	
Average	4,972	2,521	51.44	2,384	1,341	57.87

Source: CHED Higher Education Data 2014

Weakness # 8. A lesser number of qualified new entrants

According to the Fisher Report 2013, there are gaps between overall standard of seafarers output by colleges and the competency required by employers and desired by society. Newly qualified Officers often do not have the level of skill needed by employers. Fei J, Chen S, and Chen S. L. (2009) stated that there is a long-existing problem of maritime education institutions (MEI) in attracting young people into the shipping industry and there exists a high drop rate of nautical students. Moreover, Perchel (2013) mentioned that the quality of the recruits in the Philippines in some cadet academies leaves much to the desired.

Weakness # 9. Lack of Senior of Officers especially for Engine

There is underlying concern over the current and future availability of senior management level officers, especially engineers in the Far East and Indian Sub-Continent groups which includes the Philippines. Generally, there are few difficulties reported for ratings. (IMO, 2013)

Weakness #10. Issues and Gaps on Availment of Services for Seafarers

The priority welfare services of the government are financial assistance, medical coverage, free training, training/seminars on livelihood/financial literacy, retirement, seafarers' representation in Congress, and specialized agency for seafarers' needs/ grievances. However, there are issues and gaps in the acquisition of seafarers of these services such as accessibility of services and facilities, prolonged processing time, especially in the case of loans, delivery of services, coverage of programs, lack of information, handling of funds, necessity to review or upgrade the POEA contract, and absence of a retirement program for seafarers. For the welfare services of employers, welfare provisions are heavily influenced by company financial capacity, preferences and practices and company-based welfare services are provided in fragments. Other factors influencing services include priority given on position/rank on board ship, loyalty, necessity to have a personnel/section on welfare needs, and meetings, interviews, survey forms, and FGDs as methods employed to gather welfare needs of the crew. For the welfare services of seafarers' associations, the issues and gaps include long queues in the availment of medical services, insufficient medicines, limitation and exclusion of medical benefits, inadequate capacity of hostels, limitation on the coverage of survivorship

benefit, and lack of information on the programs and services offered.

Weakness #11. Lack of maritime statistical data and/or research and development

Virola et al. (2010) stated that the maritime sector encompasses a wide range of economic activities and while its importance to national development is well recognized, statistical data on these activities are generally incomplete and untimely, if not unavailable. This makes measuring the economic value of this sector difficult. As a result, policies and programs to mobilize the maritime industry as a critical driver of economic development do not benefit from high-quality information necessary to make sound and evidence-based decisions. This is agreed upon by Arcelo (2010) when he mentioned that what is critical is the inadequate documentation of the contribution of the seafaring profession is to the economy and Philippine society. Maritime industry resources and issues should be integrated into national and local development plans and policies. Virola et al. (2010) recommended for a federal maritime statistical development cooperation program that will document critical data, capacity, and deficiencies of the sector and proposed/planned solutions as well as serve as a standard reference for planning and coordination of national activities and resource mobilization. Development planning, however, must be knowledge-based. As such, policymakers should be provided with an objective source of information on the sector for better policy- and decision-making.

1. Analysis of Opportunities

Opportunity # 1. Wide industry network

According to DOLE Secretary Rosalinda Baldoz, the Philippines remains firmly stable on the IMO's 'white list' in 2011, which reflects its consistent and sustained efforts in giving full and complete effect to the IMO's revised Standards of Training, Certification, and Watchkeeping Convention (STCW '95) as amended.

The country has consistently sustained and maintained its inclusion in the "White List" in 2000, 2005, and 2009. The White List, instituted by the International Maritime Organization (IMO) in 1997, identifies the countries that have demonstrated a plan of full compliance with the STCW Convention and Code as revised in 1995. This list was developed by an unbiased panel of "competent persons" at the IMO using criteria that includes what system of certification (licensing)

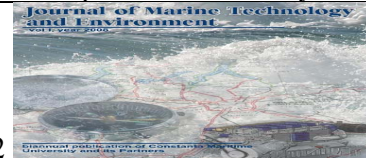

each administration would have, the process of revalidation for certificates, training center oversight, port state control, and flag state control.

(www.stcw.org) Moreover, the Philippines continue to have a relatively strong presence in various international and regional organizations. Presently, the country is a Member of Council, the policy-making body of the IMO, belonging under Category "C" which comprises of 20 IMO Member States with a keen interest in shipping. For a number of years, the country also chaired the IMO Maritime Safety Committee (MSC) and served as Conference President during the Philippine Hosting of the Conference of Parties to Adopt Amendments to the STCW Convention for Seafarers 1978, as amended and the STCW Code in June 2010. (MARINA, 2014). During the Nautical Institute (NI) Manila Command Seminar 2014, Captain David Patraiko, NI Director of Projects stated that in terms of changes in IMO which takes a lot of processes, the Philippine government as an IMO member-state has more powers to effect change than NI which is a non-government organization (NGO). (Baylon 2015). On the other hand, POEA listed 45 bilateral agreements with other countries on Filipino seafarers; two (2) on labor cooperation and 43 on recognition of Filipino seafarer's STCW certificates. Furthermore, on August 20, 2012, the Philippines became the 30th member-state of the International Labour Organization (ILO) to ratify the Maritime Labour Convention 2006, otherwise known as the Seafarers' Bill of Rights which entered into force on August 20, 2013. MLC 2006 is a global instrument adopted by the ILO on February 23, 2006, to provide for the rights and protection of seafarers. It incorporates and builds on 68 existing maritime labor conventions and recommendations, as well as more general fundamental principles, to ensure decent working and living conditions for all seafarers.

Opportunity # 2. Global Demand for Officers

In 2010, the BIMCO/ISF Manpower Update, which provides the most comprehensive assessment of the worldwide supply and demand for merchant seafarers, approximated an overall balance between supply and demand for ratings and a modest shortage of officer (2%). This report indicated deficiencies more on specialized sectors such as tankers and OSVs. Moreover, it was reported that supply would likely increase in some countries, but it was emphasized that improved training and recruitment need to be maintained to ensure a future pool of suitably qualified and high caliber seafarers. Furthermore, according to Drewry, a global shipping consultancy, shipping will require an additional 42,500 officers by the end of 2019 to cope with the expected growth in the main cargo carrying fleet, equivalent to 7% growth over the five year period. The Lead Analyst at Drewry, Malcolm Jupe, said that *"There is still a shortage of officers but the gap*

between demand and supply has narrowed as the recent growth in fleet size is coming to an end." (World Maritime News, June 24, 2015; Drewry, June 23, 2015). Consistent with the global trend, Philippines faces a shortage of officers and a surplus of ratings. Thus, the country needs to produce more officers to take advantage of the increasing employment opportunities in the global market. Locally, the country also aims to generate employment opportunities for almost half million maritime graduates and professionals not just limited to ship navigation but also in other related maritime activities such as stevedoring, ship management, shipbuilding and ship repair as well as in related maritime consultancy activities. (TESDA's Labor Market Intelligence Report 2013)

Opportunity # 3. Maritime Sponsors for Seafarers' Welfare and Development

The Philippines is provided opportunities to raise the overall standard of education and training for seafarers to international best practices through the support of maritime funders and sponsors. One of the maritime funders is the International Transport Federation (ITF) Seafarers' Trust that supports Filipino seafarers' training and welfare needs channelled through recognized associations such as the Associated Maritime Officers and Seamen's Union of the Philippines (AMOSUP), Philippine Seafarers Union (PSU), and International Seafarers Action Center (ISAC) who received ITF grants in 2013 and previous years. The Apostleship of the Sea (AOS), International Seafarer Family Convention of the Philippines, Seamen's Christian Friend Society, and other maritime organizations received support from the ITF Seafarers' Trust in previous years. (ITF Seafarers' Trust Report 2011, 2013).

Opportunity # 4 Training Opportunities for Cadets/Seafarers

The IMMAJ-PJMCC Foundation, Inc. (FINC), formerly known as PJMCC Foundation, was formed through the collaborative efforts of the International Mariners Management Association of Japan (IMMAJ) and the Philippine-Japan Manning Consultative Council, Inc. (PJMCC) who shared the common goal of advancing the quality of Filipino seafarers, especially those working onboard Japanese ships. The FINC, a non-stock, non-profit organization duly registered with the Securities and Exchange Commission (SEC) since March 7, 2003, receives grants from the JSU-AMOSUP Training Levy Fund (JATF) and the Seafarers Promotion Fund (SPF) derived from the mandatory contributions made by Japanese ship owners for the upgrading of seafarer's knowledge and skills. (<http://immajpjmccfoundation.org/about-us>). The IMMAJ-PJMCC Foundation, Inc. (FINC) has established a cadetship training program (CTP). This

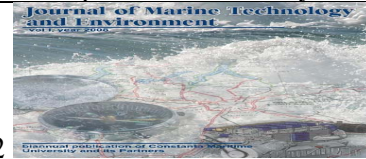

officer-development program assists PJMCC member manning agencies in recruiting and selecting qualified cadets whom the company can train and develop as future merchant marine officers and engineers for their IMMAJ member-principals. FINC has been committed to provide a steady supply of qualified officers and seafarers to the Japanese fleet through the cadetship program selected from the Maritime Academy of Asia and the Pacific (MAAP) and from the qualifiers of the Maritime School Assessment Program (MSAP). Annually, a total of 250 marine transportation and marine engineering MAAP cadets are admitted to the CTP while a total of 120 marine transportation and marine engineering cadets are taken from the passers of the MSAP nationwide examinations. (<http://immajpjmccfoundation.org/cadetship-program>). The cadets under the CTP are assigned to PJMCC member-manning agencies through raffle. These manning agencies provide them with opportunities to board international commercial vessels operated by the IMMAJ member principals also referred as “sponsor companies”. All cadets included in this program undergo training phases to complete the required 12-months shipboard training for BS Marine Transportation and BS Marine Engineering: three-month training onboard the TS Kapitan Felix Oca (TSKFO), and nine-month training onboard Japanese Principal’s international commercial vessels. They are assured of employment with their respective sponsor companies after graduation.

(<http://immajpjmccfoundation.org/cadetship-program>.) On the other hand, the International Maritime Employers’ Council (IMEC), an international employers’ organization dedicated to maritime industrial relations, established its Recruitment and Training Committee in 2006 to address the growing demand for high quality and skilled seafarers. This committee is responsible for overseeing the various IMEC training initiatives that includes the Cadet Training Enhanced Programme, Rating to Officer Scheme, and English Language Courses. In 2006, the IMEC Enhanced Cadet Training Programme was set up to address the future demand for well trained, high quality ships officers. This program takes approximately 150 cadets for this four-year programme from the University of Cebu (UC) and the Maritime Academy of Asia and the Pacific (MAAP). This program is a renowned industry leader in the training and preparation of deck and engine officer cadets and currently boasts a completion rate of over 95%. (<http://www.imec.org.uk/training/enhanced-cadet-training/members>). Similarly, the Norwegian Shipowners’ Association (NSA) has also initiated its Philippines Cadet Program which is the most outstanding and promising program of the Association of Shipowners’ Training and Education Project (ASO-ATEP). This program aims to develop young and

competent Filipino seafarers through scholarship grants and best maritime education awarded to qualified applicants. This program has tied up with the Philippine Merchant Marine Academy, John B. Lacson Colleges Foundation – Bacolod, DMMA College of Southern Philippines, and University of Cebu - Lapu Lapu and Mandaue. The NSA hopes the Cadet Program to serve as a model or instrument in the promotion of quality education in the Philippines in compliance with the STCW '95 requirements. In 2013, the program has sponsored more than 5,000 cadets graduated with Bachelors Degree in Marine Transportation and Marine Engineering respectively. (Norwegian Training Center-Manila) Moreover, other shipping companies provide sponsorship for various maritime higher education institutions (MHEIs) such as the Maritime Academy of Asia and Pacific (MAAP) with over 30 sponsoring companies.

Opportunity # 5. Upgrading Program for Ratings/Officers

On the other hand, IMEC also has the Ratings to Officer Scheme set up to assist its members in promoting good practice and to support the career progression of seafarers. IMEC offers a grant of \$1,000 per promoted seafarer to members who successfully convert a rating into an officer. Other foreign shipping companies also provide for the advancement of their Filipino crew through upgrading and training assistance.

Opportunity # 6. Training of Teachers/Trainers and Developing consistent course structures and curricula based on international best practice

On April 28-May 2, 2014, TKF Foundation Global MET Seminar-Workshop on Professional Development was conducted at MAAP, Mariveles, Bataan with the participation of 16 teachers/trainers from various Maritime Education and Training Institutions (METIs) in the country. This project aimed to identify, analyze and bridge the gap between the STCW Code (1978) as amended and the current course deliver for the marine qualifications. This TKF, GlobalMET, and MAAP-sponsored training workshop ably facilitated by Dr. Chris Haughton from UK and Capt. Richard Teo of Australia. This provided an opportunity for the participants to enhance their knowledge and skills on international best practices in education, most especially on competency-based education and training.

1. Analysis of Threats or Challenges

Threat # 1. EMSA Audit Result

A significant threat currently faced by the industry, however, is the possible ramifications of the result of the European Union - European Maritime Safety Agency (EMSA) audit. Failure in the audit results would result to banning Filipino seafaring workers to be employed in EU ships. Failure in the inspection, signals the low quality of some schools and training centers, contributing to the low attrition rate of about

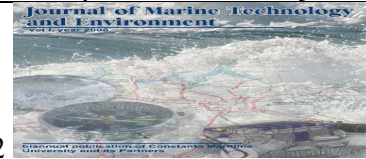

20%. In fact, among the schools audited by the EMSA, about 60 were recommended to be closed. Fortunately, the European Union had given the Philippines' Maritime Industry Authority (MARINA) more time to adjust to its new organizational structure and implement structural and policy changes to meet regulatory standards set by the 1978 International Convention on Standards of Training, Certification, and Watchkeeping (STCW) for Seafarers. Industry players are jointly working to hurdle the challenge imposed by the EMSA accreditation.

Threat # 2. Competition from Seafarer-supplying Nations in Asia and Africa

Apart from the Philippines, other countries such as India and China recognized the global demand for seafarers and may have acted on this opportunity as well. According to the Drewry's Manning Annual Report 2012 (as cited by Fisher, 2013), the supply of seafarers from critical countries such as China and India increased from 2000 to 2010. For most ships, the nationality of the seafarers is different from the country where the vessel is commercially controlled. Less than 20 percent of ratings and less than 30 percent of officers come from countries in the Organization for Economic Cooperation and Development (OECD). Seven out of the ten biggest suppliers of ratings as per the definition of the Baltic and International Maritime Council are developing countries (2010 data). China ranks first with a share of 12.1 percent, followed by Indonesia.

Increasingly, developing countries are also supplying officers. While the largest academies for marine officers have traditionally been in developed countries, the six largest suppliers today are in developing/transition economies. The Philippines still leads the ranking with 25 percent, followed by China and India; taken together, these three countries account for one-quarter of the world's supply of officers. (UNCTAD Secretariat, 2013). The Philippines and India are very significant maritime labor supply nations, with many seafarers from these countries enjoying employment opportunities on foreign flag ships operated by international shipping companies. China has also seen a significant increase in the number of seafarers, but at the moment most of these work on the Chinese fleet, meeting domestic requirements. Eastern Europe has recently become an increasingly large supplier of seafarers with high numbers from countries including the Ukraine, Croatia, and Latvia. Other major labor supply countries include Greece, Japan, Russia and the United Kingdom. (International Chamber of Shipping).

7. SUMMARY AND CONCLUSIONS

The SWOT Analysis of the Philippine Manning Industry is summarized in Table 1 with various issues that need to be addressed

Table 1: SWOT Analysis of Philippine Manning Industry

Strength (12)	Weaknesses (11)
<ul style="list-style-type: none"> • International recognition as manning capital of the world • High rate of deployment • Increase in the Number of Principals Engaged in Manning Agencies • High remittance contribution of seafarers • Increase in the number of maritime enrollees and graduates • Large manpower pool of ratings and officers • Availability of welfare services for seafarers • Improvement/Streamlining in the Philippine Maritime Administration • Unified front liners - Strong private-public partnership to promote seafarers competency • Availability and recognition of quality/excellent manning agencies • Reforms in MHEIs for better industry workforce entrants • Close monitoring of accredited maritime training centers 	<ul style="list-style-type: none"> • Diverse issues and concern with the new regulations in compliance to STCW 2010 • Lack of government support for seafarers' education • Inadequacy of equipment and facilities in MHEIs • Inadequacy of qualified trainers/teachers in MHEIs • Gaps and issues on maritime education output and the needs of the industry • Lack of berths for cadet training program • Decrease in the number of licensure examination takers • Lack of Senior of Officers especially for Engine • Lesser number of qualified new entrants • Issues and gaps on the availment in welfare services for seafarers • Lack of statistical data and/or research and development in the maritime sector
Opportunities (6)	Threats (2)

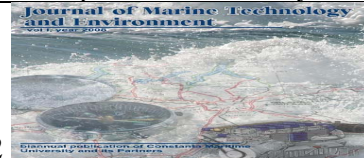

<ul style="list-style-type: none">• Wide Industry Network• Global demand for officer• Availability of maritime funders and sponsors• Training opportunities for cadets/seafarers• Upgrading for ratings/officers• Training opportunities for trainers/teachers and Developing consistent course structures and curricula based on international best practice	<ul style="list-style-type: none">• Implications of EMSA Audit Result• Potential competition from other seafarer-supplying nations in Asia and in Africa in the future- Need to sustain the supply in light of socio-economic changes in the Asia Pacific over time-Structural failure in the market for seafarer training- Lack of coordination/vision to sustain the Philippine position as the lead supplier of seafarers
--	--

Considering that that the data generated were recent and fresh directly from concerned agencies, maritime leaders; manning personnel/seafarers, it is hoped that the result of this SWOT analysis will serve as a basis by all concerned interested in the affairs of the maritime industry to maintain the status of the Philippines as the Manning Capital of the world

Acknowledgment

National Research Council of the Philippines (NRCP) for the 1-year research grant.

8. REFERENCES

1. ADB & ADBI. (2003). Connecting South Asia and Southeast Asia: Interim Report. Tokyo: Asian Development Bank Institute
2. Arceles, Adriano A. (2010). National Statistics on ICT, Shipping Industry, and the Maritime Profession: Its Applications in Business and Industry and Philippine Society. Paper presented at the 11th National Convention on Statistics, October 4-5, 2010, EDSA Shangri-la Hotel, Ortigas Center, Mandaluyong City, Philippines.
3. Asis, Maruja M.B. & Go, Stella P. (2014). An Assessment of the Philippine Overseas Employment Administration's (POEA) agency performance awards. International Labour Organization, ILO Country Office for the Philippines. - Makati City: ILO, 2014 ISBN: 9789221287834; 9789221287841 (web pdf)
4. Banko Sentral ng Pilipinas (2015). **Overseas Filipinos' Remittances**. Retrieved from http://www.bsp.gov.ph/statistics/efs_ext3.asp on May 15, 2015.
5. Baylon, A.M. (2002), "*The Manning Industry Behavior and Its Impact on the Philippine Economic Development: An Analysis*" an Unpublished thesis from Philippine Merchant Marine Academy for the degree in Master in Shipping Business Management pp 1-232.
6. Baylon, A.M. & E.M.R. Santos (2011). "*Challenges in Philippine Maritime Education and Training*" in International Journal of Innovative Interdisciplinary Research ISSN 1839-9053, pp 34-43. Retrieved from <http://www.auamii.com/jiir/Vol-01/issue-01/X5.Baylon.pdf> on August 15, 2014
7. Borromeo, Gerardo A. 2014. Asia-Pacific Manning and Training Conference Summary Report. November

- 26-27, 2014. Sofitel Philippine Plaza Manila. Taken from www.manningandtraining.com retrieved on January 15, 2015
8. BIMCO (2010). Manpower 2010 Update. The Worldwide Demand for and Supply of Seafarers. Retrieved from www.marisec.org/Manpower%20Study.pdf on August 8, 2012.
9. Cacadac, Hans Leo J. (2014). POEA: Standard Employment Contract, Deployment Issues and Concerns: How to Maintain the Filipino Seafarers as the World's Number One at Present and Beyond? Seafarers Forum, Philippine National Library, April 30, 2014
10. Commission on Higher Education (CHED) (2014). Higher Education Data: 2014. Public and Private HEIs. Retrieved from <http://www.ched.gov.ph/wp-content/uploads/2014/temp/10-03/home/Higher%20Education%20Data%202014%20-%20Public%20and%20Private%20HEIs.pdf> on May 5, 2015
11. Commission on Higher Education (CHED) (2012). Policy-Standard to Enhance Quality Assurance (QA) in Philippine Higher Education Through An Outcomes-Based and Typology-Based QA. CHED Memorandum Order (CMO) No. 46, series of 2012. Retrieved from www.ched.gov.ph on September 15, 2014
12. Commission on Higher Education (CHED) (2013). Rules and Procedures implementing the CHED and MARINA joint monitoring of maritime education programs offered by maritime higher education institutions. CMO No. 27 series of 2013
13. Commission on Higher Education (CHED) (2014). CHED priority courses for 2014-2015 to AY2017-2018. CMO No. 01, series 2014.
14. MBC Congress Watch Report. Ensuring Competitiveness of the Philippine Seafaring Industry. Report No. 182. April 7, 2014. Retrieved from www.mbc.com.ph on June 13, 2014
15. Department of Energy. Current Industry Structure (2012). Retrieved from https://www.doe.gov.ph/microsites/ngmd%20website/in_d_current_structure.html on December 9, 2014
16. Department of Energy. Exploration Opportunities in the Philippines (2012). Retrieved from <https://www.doe.gov.ph/microsites/pecr4/petroleum.html> on December 10, 2014

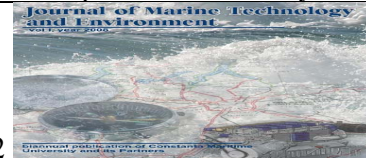

Journal of Marine technology and Environment Year 2018, Vol.2

16. Department of Labor and Employment (DOLE) (2012). PH maintains IMO 'white list' standing, has updated EMSA on compliance with audit recommendations. Date Posted: February 21st, 2012. Retrieved from <http://www.dole.gov.ph/news/view/1655> on May 15, 2014
- DOLE (2012). Project JobsFit Summary of Findings and Recommendations. Retrieved from <http://www.ble.dole.gov.ph/pjf/finalreport.pdf> on September 15, 2014
- Drewry (2015). Shortage of Ship Officer Crew Receding. London, UK, 23 June 2015. Retrieved from <http://www.drewry.co.uk/news.php?id=375> on July 6, 2015
- Fei J, Chen S, and Chen S. L. (2009) "Organizational Knowledge Base and Knowledge Transfer in the Shipping Industry" *Electronic Journal of Knowledge Management* Volume 7 Issue 3, (pp325 - 340), available online at www.ejkm.com retrieved on August 15, 2014
- Filipino Association of Maritime Employers (FAME). About Us – History, President's Corner. Retrieved from www.fame.org on September 15, 2014
- Fisher Assoc. Ltd (t/a/ Fisher Associates). (2013). Human Resource Development in the Maritime Sector in Asia and the Pacific. ADB Seafaring Strategic Review. Retrieved from [http://www.globalmet.org/images/ADB%20HRD%20Seafaring%20Strategic%20Review%20Final%2014-6-13\(low\).pdf](http://www.globalmet.org/images/ADB%20HRD%20Seafaring%20Strategic%20Review%20Final%2014-6-13(low).pdf) on May 2, 2014
- Fleener, John W. (2006). Trait Approach to Leadership. Encyclopedia of Industrial and Organizational Psychology. Sage Publications. 16 February 2011
17. International Chamber of Shipping (2015). Number and Nationality of World's Seafarers. Retrieved from <http://www.ics-shipping.org/shipping-facts/shipping-and-world-trade/number-and-nationality-of-world-s-seafarers> on April 15, 2015
18. International Chamber of Shipping (2015). International Chamber of Shipping Annual Review 2015. Retrieved from <http://www.ics-shipping.org/docs/default-source/resources/policy-tools/ics-annual-review-2015.pdf?sfvrsn=8> on May 15, 2015
19. International Labour Conference. Maritime Labour Convention, 2006
20. International Maritime Organization (IMO) (2012). International Shipping Facts and Figures – Information Resources on Trade, Safety, Security, Environment. Maritime Knowledge Centre. 6. March 2012. Retrieved from www.imo.org on February 15, 2015
21. International Maritime Employers' Council (IMEC). The IMEC Enhanced Cadet Training Programme. Retrieved from <http://www.imec.org.uk/training/enhanced-cadet-training/members> on February 17, 2015
22. Invest Philippines (2015). Shipbuilding. Retrieved from <http://investphilippines.gov.ph/industries/manufacturing/shipbuilding> on January 28, 2015
23. ITF Seafarers' Trust (2013). The ITF Seafarers' Trust Trustees' Report and Financial Statements for the Year ended 31 December 2013. Charity Number: 281936. Retrieved from <http://www.seafarerstrust.org/files/extranet/-/1/44470/Seafarers%27%20Trust%20Annual%20Report%202013.pdf> on October 15, 2014
24. ITF Seafarers' Trust (2011). The ITF Seafarers' Trust Trustees' Report and Financial Statements for the Year ended 31 December 2011. Charity Number: 281936. Retrieved from <http://www.seafarerstrust.org/files/extranet/-/1/36592/Seafarers%27%20Trust%20Annual%20Report%202011.pdf> on October 16, 2014
25. IMMAJ-PJMCC Foundation Inc. (2013). The IMMAJ-PJMCC Cadetship Program. January 11, 2013. Retrieved from <http://immajpjmccfoundation.org/cadetship-program> on October 17, 2014
26. IMMAJ-PJMCC Foundation Inc (2014) About IMMAJ-PJMCC Foundation Inc. taken from <http://immajpjmccfoundation.org/about-us> retrieved on October 18, 2014
27. Joint Manning Group (JMG) (2014). History. Retrieved from www.jobs-marino-go.com on October 19, 2014
28. Kirkpatrick, S.A. and E.A. Locke (1991). "Leadership: Do Traits Really Matter?" *Academy of Management Executive*, May 1991, pp. 48–60.
29. Koh, Quintella (2013). The Philippines Pushes Ahead with Offshore Development Efforts. February 14, 2013. Retrieved from http://www.rigzone.com/news/oil_gas/a/124321/The_Philippines_Pushes_Ahead_with_Offshore_Development_Efforts#sthash.iF6ciCLF.dpuf on September 10, 2014
30. Lanto, N. (2012). Opportunities or Woes? Situationer of the Overseas Seafaring Labor Landscape. Pre-Employment Services, Philippine Overseas Employment Administration. *Unpublished Presentation* during the National Seafarers Convention, June 25 – 26, 2012
31. Laing, Mark (2013). Small Business Quick Guide to Understanding a SWOT Analysis. Formidable Business Pty Ltd/ Fast Track Coaching, Blackburn Victoria, Australia. Retrieved from <http://tinyurl.com/opvn6xb> on May 26, 2015
32. Lee, J.-W & Mckibbin, W. (2014). Service Sector Productivity and Economic Growth in Asia. ADBI Working Paper 490. Tokyo: Asian Development Bank Institute. Retrieved from <http://www.adbi.org/working-paper/2014/07/18/6358.service.sector.productivity/> on January 27, 2015
33. Maritime Industry Authority (2010). MARINA Accomplishment Report 2010. Retrieved from www.marina.gov.ph retrieved on January 28, 2015

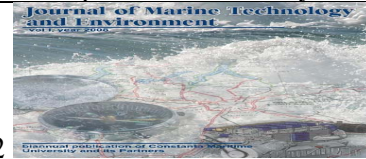

Journal of Marine technology and Environment Year 2018, Vol.2

34. Maritime Industry Authority (2011). MARINA Accomplishment Report 2011. Retrieved from www.marina.gov.ph retrieved on January 28, 2015
35. Maritime Industry Authority (2012). MARINA Accomplishment Reports 2012. Retrieved from www.marina.gov.ph retrieved on January 28, 2015
36. Maritime Industry Authority (2013). MARINA Accomplishment Reports 2013. Retrieved from www.marina.gov.ph retrieved on January 28, 2015
37. Maritime Industry Authority (2014). MARINA Accomplishment Reports 2014. Retrieved from www.marina.gov.ph retrieved on January 28, 2015
38. Maritime Industry Authority (2013). The Philippine Maritime Industry: Prospects And Challenges In 2013 And Beyond. Retrieved from http://marina.gov.ph/reports/other_reports/Philippine%20Maritime%20Industry.Prospects%20and%20Challenge%20s.pdf on September 4, 2014
39. Maritime Industry Authority (2013). Revised Rules on the Accreditation of Instructors and/or Assessors.
40. MARINA Circular No. 2013-12 Series of 2013. Retrieved taken from <http://www.marina.gov.ph/policies/MCs/MC%202013-12.pdf> on September 5, 2014
41. Maritime Industry Authority (2015). Technical Panel on Maritime Education Continues Review. MARINA News Digest. Issue 2. April 13, 2015. Retrieved from <https://phmarina.wordpress.com/technical-panel-on-maritime-education-continues-review/> on May 30, 2015
42. .MBC Congress Watch Report (2014). Ensuring Competitiveness of the Philippine Seafaring Industry. Report No. 182. April 7, 2014. Retrieved from www.mbc.com.ph on January 15, 2015
43. Morfardini, Erica, L. Probst, et. al.(2012). Emerging Industries Report on the Methodology for their Classification and on the Most Active, Significant and Relevant New Emerging Industrial Sectors. European Union, July 2012.
44. NMP (2013). Challenges Facing Seafarers' Welfare: An Analysis of Current Welfare Programs vis-à-vis Seafarers' Needs - A collaborative research undertaking among the National Maritime Polytechnic (NMP), Overseas Workers Welfare Administration (OWWA) and Associated Marine Officers' and Seamen's Union of the Philippines (AMOSUP). Presented on October 10, 2013. Diamond Suites and Residences Cebu City. Retrieved from <http://www.nmp.gov.ph/uploads/ChallengesPresentation.pdf> on October 5, 2014
45. Norwegian Training Center- Manila. NSA Philippines Cadet Program. Retrieved from <http://ntcmanila.com/cadet-program.php?id=9> on September 5, 2014
46. Padilla, M. J. & R. E. Eguia (2010). Relative Efficiency of Seaports in Mindanao. Paper Presented in the 11th National Paper presented at the 11th National Convention on Statistics, October 4-5, 2010, EDSA Shangri-la Hotel, Ortigas Center, Mandaluyong City, Philippines. Retrieved from http://www.nscb.gov.ph/ncs/11thNCS/papers/invited%20papers/ips-12/01_Relative%20Efficiency%20of%20Seaports%20in%20Mindanao.pdf on October 6, 2014
47. Partnerships in Environmental Management for the Seas of East Asia (PEMSEA). Philippines. Retrieved from <http://www.pemsea.org/philippines> on April 15, 2015
48. Perchel, Waldemar (2013). The 16th European MANNING & TRAINING CONFERENCE Dubrovnik, Croatia
49. Philippine Government (2013). Investment Priority Plan 2013. Retrieved from <http://www.gov.ph/downloads/2013/11nov/20131113-MO-0059-2013-IPP.pdf> on August 1, 2014
50. Philippine Ports Authority (PPA) (2013). PPA Annual Report. Retrieved from www.ppa.gov.ph on February 3, 2015
51. Philippine Ports Authority (PPA) (2013). Summary on Port Performance 2013. Retrieved from http://www.ppa.com.ph/Port%20Statistics/PortPerformance/2013_SummaryPortPerformancefrm.htm on March 4, 2015
52. PPA (2014). Summary on Port Performance 2014. Retrieved from http://www.ppa.com.ph/Port%20Statistics/PortPerformance/2014_SummaryPortPerformancefrm.htm on March 1, 2015
53. Philippine Overseas Employment Administration (POEA). Bilateral Labor Agreements for Filipino Seafarers. Retrieved from www.poea.gov.ph/blas/BLA_Seafarers.pdf on February 10, 2015
54. Philippine Overseas Employment Administration (POEA) (2011). POEA Annual Report 2011
55. Philippine Overseas Employment Administration (POEA), 2013. Memorandum Circular No. 03, Series of 2013 (Agency Performance Evaluation and Conferment of Awards). Retrieved from <http://www.poea.gov.ph/MCs/MC%202013/MC-03-2013.pdf> on September 18, 2014
56. Philippine Overseas Employment Agency (POEA) (2013). Deployment Statistics 2013. Retrieved from http://www.poea.gov.ph/stats/2013_stats.pdf on September 19, 2014
57. Philippine Overseas Employment Administration (POEA), (2014). President Aquino III fetes outstanding licensed recruitment agencies taken from http://www.poea.gov.ph/news/2014/pr_feb2014_agency_awards.pdf retrieved on September 20, 2014
58. Philippine Overseas Employment Agency (POEA). Bilateral Labor Agreements for Filipino Seafarers. Available taken from http://www.poea.gov.ph/blas/BLA_Seafarers.pdf, retrieved on September 21, 2014

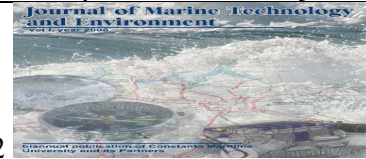

Journal of Marine technology and Environment Year 2018, Vol.2

59. Philippine Statistics Authority (2014). 2012 Census of Philippine Business and Industry - Transport and Storage for Establishments with Total Employment of 20 and Over: Final Results. Reference Number: 2014-98. Release Date: Monday, December 29, 2014. Retrieved from <https://psa.gov.ph/content/2012-census-philippine-business-and-industry-transport-and-storage-all-establishments-final> on January 18, 2015
60. Philippine Statistics Authority (2014). 2012 Census of Philippine Business and Industry - Transport and Storage for Establishments with Total Employment of 20 and Over: Preliminary Results. Reference Number: 2014-36. Release Date: Thursday, May 22, 2014. Retrieved from <https://psa.gov.ph/content/2012-census-philippine-business-and-industry-transport-and-storage-establishments-total> on June 2, 2015
61. Posner, K. & M. Applegarth (2000). Project Management Pocketbook. UK: Alresford Press Ltd 1998) p.19
62. Robbins, S. P., & Coulter, M. (2005). Management (8th Edition), Pearson Education, Inc.
63. Slaski, R.J, Maguire, S, and Al-Mahmood, A (2013). European Maritime and Fisheries Fund (EMFF) 2014-2020 United Kingdom SWOT and Needs Assessment Analysis. Epsilon Resource Management. July 2013
64. Sereño, M.N.V. (2012). Effects of International Remittances on the Philippine Economy: A Cointegration Analysis. DLSU Business and Economic Review. De La Salle University. 21.2. pp 47-62
65. Shipping & Ports Group (2011). Challenge to the Industry: Securing Skilled Crews In Today's Marketplace. Deloitte Touche Tohmatsu Limited. Retrieved from [https://www2.deloitte.com/content/dam/Deloitte/global/Documents/dttl-er-challenge industry-08072013.pdf](https://www2.deloitte.com/content/dam/Deloitte/global/Documents/dttl-er-challenge%20industry-08072013.pdf) on February 5, 2015
66. STCW.ORG. Maritime Labour Convention (MLC). Retrieved from www.stcw.org on February 15, 2015
67. STCW.ORG (2014). What is the "White List"? Retrieved from www.stcw.org on September 14, 2014
68. TESDA (2013). Labor Market Intelligence Report: Skills Demand and Supply Mapping. Retrieved from [http://tesda.gov.ph/uploads/File/Planning2014/LMIR/LMIR%20\(5\)%20Skills%20Demand%20Mapping_Final.pdf](http://tesda.gov.ph/uploads/File/Planning2014/LMIR/LMIR%20(5)%20Skills%20Demand%20Mapping_Final.pdf) on February 27, 2015
69. The World Bank (2015). Philippine Economic Update. Making Growth Work for the Poor. Report No. 93530-PH. January 2015. Retrieved from <http://www.worldbank.org/content/dam/Worldbank/document/EAP/Philippines/PEU%20Jan%202015%20PDF.pdf> on February 15, 2015
70. UNCTAD (2012). UNCTAD Review of Maritime Transport 2012. UNCTAD/RMT/2012. United Nations Publication. Sales no. E.12.II.D.17. ISBN 978-92-1-112860-4. e-ISBN 978-92-1-055950-8. ISSN 0566-7682
71. UNCTAD (2013). UNCTAD Review of Maritime Transport 2013. UNCTAD/RMT/2013. United Nations Publication. Sales no. E. 13.II.D.9. ISBN 978-92-1-112872-7. e-ISBN 978-92-1-054195-4. ISSN 0566-7682
72. UNCTAD (2014). UNCTAD Review of Maritime Transport 2014. UNCTAD/RMT/2014. United Nations Publication. Sales no. E.14.II.D.5. ISBN 978-92-1-112878-9. ISBN 978-92-1-056861-6. ISSN 0566-7682
73. UNCTAD Secretariat (April 5, 2013). Recent developments and trends in international maritime transport affecting trade of developing countries. Taken from http://unctad.org/meetings/en/SessionalDocuments/cid30_en.pdf Retrieved from May 14, 2015
74. Virola, et. al. (2010). Towards A Satellite Account on the Maritime Sector in the Philippine System of National Accounts: Preliminary Estimates. Presented in the 11th National Convention on Statistics (NCS). EDSA Shangri-La Hotel, Manila. October 4-5, 2010. Retrieved from http://www.nscb.gov.ph/ncs/11thNCS/papers/invited%20papers/ips-19/02_National%20Statistics%20on%20ICT,%20Shipping%20Industry%20and%20the%20Maritime%20Profession%20Its%20Applications%20in%20Business%20and%20Industry%20and%20Philippine%20Society.pdf on October 20, 2014
75. Wignaraja, G, Morgan, P, Plummer, M & Zhai, F (2014). Economic Implications of Deeper South Asian-Southeastian Integration: ACGE Approach. ADBI Working Paper 494. Tokyo: Asian Development Bank Institute. Retrieved from <http://www.adbi.org/working-paper/2014/08/08/6373.economic.implications.asian.integration/> on November 1, 2014
76. World Maritime News (2015). Shipping Will Need 42,500 Officers by 2019. June 24, 2015. Retrieved from <http://worldmaritimeneews.com/archives/164515/shipping-will-need-42500-officers-by-2019/> on July 15, 2015

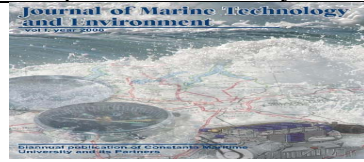

ISSUES IN THE HANDLING OF A MULTI-MASTED SAILING VESSEL IN VARIOUS HYDRO-METEOROLOGICAL CONDITIONS

Yuriy Dachev¹ & Ivo Lazarov²

¹Nikola Vaptsarov Naval Academy, Navigation Department, 73 Vasil Drumev Str., 9026, Varna, Bulgaria,
e-mail address: urida@abv.bg

²Nikola Vaptsarov Naval Academy, Navigation Department, 73 Vasil Drumev Str., 9026, Varna, Bulgaria,
e-mail address: ivolazarov63@yahoo.com

Abstract: Navigation under sail has been known to people for at least a thousand years, having evolved with the advance of mankind, where the quest has always been towards shortening sailing time by optimal routing and pursuing top speed. With the development of computer technologies and automation in shipping, the art of conning a sailing craft has been transformed and enhanced to a new level. Great consideration is now given to the protection of the marine environment and the atmosphere from the ever-increasing carbon emissions, which has resulted in the rediscovery of wind-powered navigation. It is worth noting that the global demand for and purchases of medium and large sailing boats and motor yachts with sails have plummeted over the last 10 - 15 years. The effect of wind and seas on sailing ships operation is disproportionately greater compared to motor-driven vessels. For the purposes of safe navigation sailing crews must closely observe the parameters of sailing vessels' movement, hydro-meteorological conditions and navigational aids' operation. They provide essential information of the ship's position, course, heel angle and rudder angle, distance made good, the elements of the hydro-meteorological conditions as well as forthcoming weather forecast, etc. Present-day sailing relies on these parameters for the normal operation of the various automatic systems used in the handling of sailing vessels. A universal automatic system has not yet been developed that would incorporate all factors at play in the safety of sailing in such a dynamic environment. The modelling of such a system will ensure the safe and optimal movement of multi-masted sailing vessels, regardless of the hydro-meteorological conditions in the navigation area.

Key words: hydro-meteorological conditions, optimal sail angle, sail area, sailing vessel, tacking.

1. INTRODUCTION

Hydro-meteorological conditions may present problems for the navigational safety of sailing ships and significantly prolong their passage. In order to secure safe and shorter routes, the crew must take into account both the navigational and hydro-meteorological conditions prevailing in the sailing area, such as wind, sea and currents.

Finding the shortest sailing distance between two points along the route can be achieved through different navigational methods: steering along rhumb lines between waypoints, following a great-circle track, etc.

Frequently the shortest path chosen may not prove the most optimal in time and may pose risks to the navigational safety. Wind, sea and currents may contribute to increasing sailing time as a result of speed reduction and deviation from planned courses.

Sailing vessels must tack along the pre-planned general course between waypoints in head wind and

must choose the optimal sail angle and sail area in order to reach maximum speed. The best angle of attack and sail's area must be calculated in head wind as well.

The situation is considerably more complicated providing sailing is to be done in adverse hydro-meteorological conditions, where keeping an optimal course and speed often leads to emergency situations, such as vessel capsizing, loss of masts, spars, rigging, etc.

2. A GROUP OF FACTORS AFFECTING THE HANDLING OF A SAILING VESSEL

All vessels including sailing ships are at the mercy of external conditions formed by the wind, waves, currents and depths in the navigation area. In order to optimize the ship's movement, consideration must be given to constant and variable external factors alike. They must be linked to functional dependencies, taking into account the seaworthy properties of the sailing ship

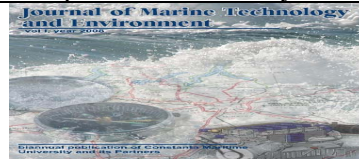

in given hydro-meteorological conditions. External forces cannot be altered, unlike the ship's course as well as the angle of the air flow over the sails.

2.1 Wind direction and speed

Wind is considered among the main factors at play. The person handling a sailing vessel must be capable of assessing whether the wind is continuous or intermittent. This is crucial to preserving the ship's seaworthy condition.

In continuous wind it is easy to reach the desired balance of the sailing ship, namely to have her on an even keel and proceed at a steady speed. With continuous winds, however, it must be born in mind that their speed and sometimes even direction vary at different heights. Low winds are usually lighter and the air flow is not always stable as they encounter various obstructions. High altitude winds are not as mixed and often have a more stable direction.

The force of the wind over the sails is the force acting at the end of heeling arm at the center of the sail area. The location of the center of sail area depends on the number of sails used at a given time and the position of the sails into the wind.

The sails of sailing ships operate according to two principles: by air flow and by laminar flow. According to the first principle the wind blows over the sails, pushing with two types of pressure. If the wind is viewed as a fluid, the Bernoulli's principle is in force, which states that an increase in the speed of a fluid occurs simultaneously with a decrease in pressure. Bernoulli's principle can be derived from the principle of conservation of energy, which states that at every point of a current line the full mechanical energy is the same. Thus an increase in the speed of the fluid – implying an increase in its kinetic energy (dynamic pressure) – occurs with a simultaneous decrease in (the sum of) its potential energy. A common form of Bernoulli's equation, valid at any arbitrary point along a streamline, is [8]:

$$\frac{v^2}{2} + G \cdot Z + \frac{p}{\rho} = const \quad (1)$$

where:

- V is the fluid flow speed at a point on a streamline;
- G is the acceleration due to gravity;
- Z is elevation above the earth surface;
- P is the atmospheric pressure;
- ρ is the density of the fluid.

As a result of the airflow over the sails two zones are formed: one with high pressure and another with low pressure. If different pressure is applied in the equation, it will be seen that in order to fulfill the

equation, the velocity must change inversely proportionally. (Figure 1)

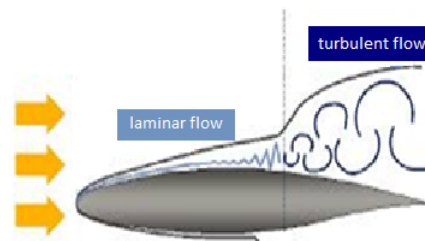

Figure 1 Airflow over the sail

The second way the sail operates is through pressure. In this case, the airflow encounters the sail area and transmits its kinetic energy over to the sail's potential. After it is reduced to a pulling force, causing the drift of the vessel, the ship is navigated in the desired direction.

Regardless of the type of wind action its speed is of utmost importance. Every sailing boat is designed to sail when the wind speed does not exceed certain limits. When the speed of the wind is greater than this limit, sailing is considered to be done in heavy conditions. There are several ways to reduce the wind force over the sails. One way to do so is to change the course angle. This can be achieved by adjusting the sheets or by altering the ship's course relative to the wind.

The ship is perceived as a system of many units, each one having its own endurance properties. The marginal force of the wind depends on the strength of the system's weakest element.

2.2 Sea wave formation and movement

Sea wave formation and movement are also to be regarded as part of the hydro-meteorological conditions affecting sailing. Waves are generated by the wind and the wind pressure on the sea water. The effect of the wind on the sea surface is analogous to the effect of the wind on a wheat field. The water particles do not move along with the wave, they only rise and fall, moving not just vertically up and down, but in closed orbits resembling circles. The actual shifting of the water mass is indeed very little. It rather oscillates around its equilibrium position, where the displacement of water mass leads to a change in the wave crest, which determines the wavelength (λ) and its period (t).

Wave height is crucial to sailing as currents are formed on the water, which speed and direction vary across the sea surface. At the wave crest, the current coincides with the movement of the wave, however, at the wave trough, it goes backwards in relation to the movement of the waves. The intensity of this surface current is proportional to its velocity. Therefore, the effect of the surface current on a sailing ship will vary

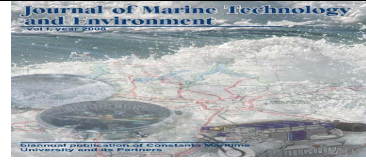

depending on her course, the ratio of the wavelength (λ) to the length of the ship (L) and the position of the hull relative to the wave.

For instance, a vessel sailing close-hauled, crossing the wave at an angle, will be pushed by the surface current on a greater course angle to the wind. A vessel sailing broad reach will bear away further to a dead run. Yet in another area, the effect of the same surface current will divert the sailing ship from her course and force the helmsman to work hard at the wheel just to keep the ship on her track. Normally only shallow water layers are affected by the sea. As the depth increases, the sea diminishes and finally subsides. Hence, currents are more pronounced on the sea surface.

It is important to analyze the ship's sailing in waves according to two scenarios: sailing against the wave and in the direction of the wave.

Normally, sailing against the wave is associated with sailing at a sharp angle to the wind. When a ship sails in calm seas, she overcomes the hydrodynamic resistance (drag), which remains relatively constant in set wind. Then the movement of the ship is said to be smooth. But quite another situation is to ply windward. In that case owing to the periodic variation of the hydrodynamic resistance, the ship will not be moving smooth and her average speed will be less than in the former case. Sailing against the wave involves an additional resistance, which can significantly aggravate voyage performance. When tacking and sailing against the wave, the vessel experiences a change of trim due to the impact of waves over the hull. As a result of slamming there is a risk of structural damage to the fore end of the vessel. Slamming is the impact on the forward bottom part of the hull from the ship's falling onto the waves.

Another negative consequence from the change of trim is reduced steerage, as the rudder rises above the sea surface. The rudder is rendered ineffective as the water flow over it is decreased. According to Bernoulli's principle, as the water flow over the rudder is reduced, the forces that turn it are also reduced.

When the vessel sails on a course that coincides with the direction of the waves, regardless of a continuous wind, her speed may increase or decrease as she moves over the crest and trough of the wave.

Another danger when sailing down the wind is the risk of matched resonance frequency, where the wavelength matches the length of the hull, and the speed of the wave matches the speed of the ship. Under these circumstances the ship has reduced stability and steerage, resulting in a reduction in the moment of inertia of the waterline (I_x), which in turn leads to a decrease in the metacentric radius (BM):

$$BM = \frac{I_x}{v} \quad (2)$$

A reduced radius BM means a lower transverse metacentric height (GMt) resulting in reduced ship's stability. Most distress communication at sea has been largely as a result of loss of stability.

2.3 Water resistance

The movement of a sailing vessel through the water is estimated in ideal hydro-meteorological conditions as well as in calm sea where a given speed can be reached in the absence of heavy seas. Since perfect weather conditions are practically non-existent, the actual speed made good (SOG) is always less than the estimated one.

The reduction in speed is due to the hydrodynamic resistance, consisting of two components: frictional resistance and wave resistance.

Regardless of the sailing vessel size, the resistance due to friction can be calculated with the formula [1]:

$$R_{fr} = (\zeta_{f_0} \cdot K + \zeta_c) \rho \cdot V_{\Omega}^2 \frac{\Omega}{2} \quad (3)$$

where: ζ_{f_0} is coefficient of friction;

K is coefficient of the effect of the curve, ranging between 1.02 - 1.08;

ζ_c is correlation coefficient, ranging between 0.2 - 0.5;

ρ is water density in kg/m^3 ;

Ω is wetted surface in m^2 .

For wave resistance (R_w) the equation is as follows [2]:

$$R_w = \gamma \cdot L^3 \cdot Fr \quad (4)$$

where: γ is specific water weight in t/m^3 ;

L is ship's length in metres;

Fr is the Froud number. [3]

3. A MODEL OF AN AUTOMATIC SYSTEM FOR HANDLING A SAILING VESSEL IN VARIOUS HYDRO-METEOROLOGICAL CONDITIONS

In recent years, a number of ship information systems have been developed worldwide for the purposes of safe and efficient navigation. They are intended to facilitate crews and supply maximum information when sailing on a planned route. These information systems assist in adjusting the course during voyage, and can solve various navigational tasks related to the completion of passage plans. [4], [5], [6], [7]

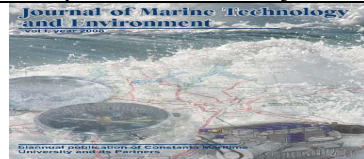

Journal of Marine Technology and Environment Year 2018, Vol.2

To be fully operational these systems should incorporate a set of sensors and equipment: a satellite navigation system receiver, an electronic magnetic compass, a gyrocompass, a satellite compass, accelerometers, roll and pitch motion sensors, rudder speed deflection sensor, Automatic Identification System (AIS), Automatic Radar Plotting Aids (ARPA), etc. However, the conning bridge on board sailing vessels is quite specific as opposed to motor-driven vessels', and mounting all instruments, devices, systems and sensors can prove an impossible task as crucial as they are to safety.

There are different sailing instruments available, to assist in the handling of sailing ships, provided by various manufacturers such as B&G [9], Raymarine, Garmin [10], etc. They update the crew about the vessel's current parameters but do not contain particular advice on sail trimming, options for optimal routing and reading of the actual speed made good. These sailing instruments do not take into account the change of wind and offer no guidance on optimal heel.

With the advance of computer technologies, new sailing navigation applications have been developed, such as Sail Timer, Sail Racer, Navigatta, Deckman, to help solve certain problems encountered in navigation under sail, which also provide instructions on the point of sail along a given route in check with the wind profile. The main drawback of these automatic sailing applications is that they do not take into account any change in the external conditions as well as the particulars of each sailing vessel, thus rendering themselves ineffective in the event of a dynamic change at sea for the purposes of navigational safety.

Nowadays the solving of issues related to the handling of a multi-masted sailing ship relies on different theoretical patterns of movement, developed on the basis of efficient methods and systems where the emphasis is placed on one or more external factors.

All efforts in the research of sailing theory and practice are primarily focused on the possibilities of optimizing and improving sail trimming as well as on the ship's steering aids. [11], [12], [13]

Although relative success in this respect has been achieved, there is still a present need for the development of mathematical models and algorithms for sail trimming depending on wind change. This issue has not been sufficiently researched and modern-day sailing still predominantly relies on the experience and expertise of the Master and crew.

The major drawback of the research and publications presently available is the absence of a more integrated automatic system for handling sailing vessels. There are no technical solutions proposed for navigating sailing ships along a planned route that would consider the influence of all types of external factors and their interaction.

The development of a mathematical model for the handling of multi-masted sailing ships has become an important task in sailing practice. The task demands the creation of algorithms for ship handling and the choice of sailing route, that take into account the combined effects of wind, seas and ship's heel, while simultaneously processing the data coming from the equipment and the systems.

The present paper proposes a block diagram (Figure 2) on the handling of multi-masted sailing ships, where all factors involved have been integrated.

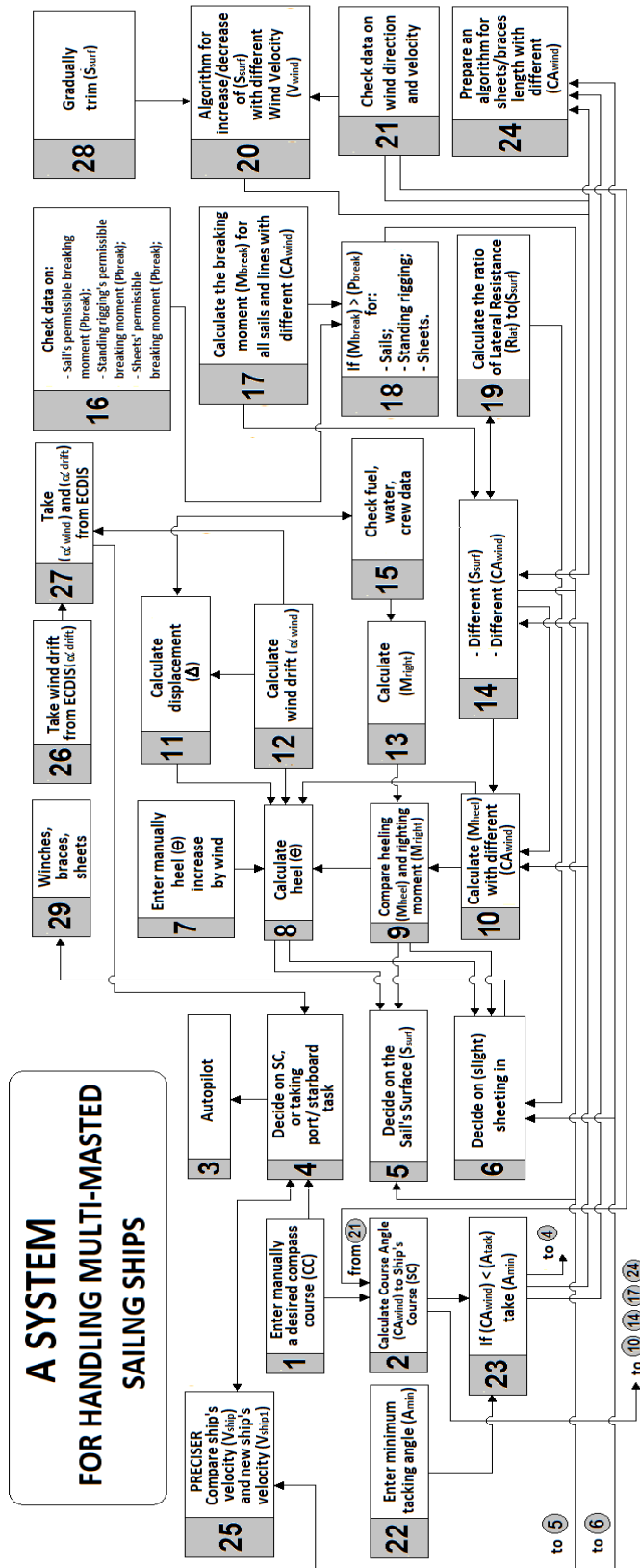
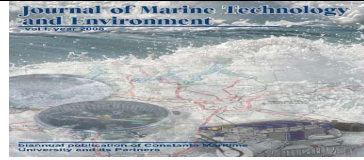
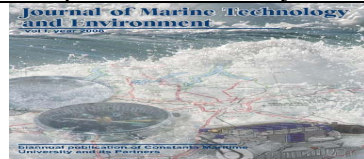

Fig. 2 A block diagram of a system for handling of multi-masted sailing ships



4. CONCLUSIONS

The application of a mathematical model for the handling of multi-masted sailing vessels would reduce the dependence of navigational safety solely on the level of expertise of the Master and crew. It would decrease the likelihood of human factors errors when making decisions about the navigation of sailing ships in rough seas.

The mathematical model for the handling of sailing ships can serve as a basis for designing a training simulator for sailing crews that would check crew members' response in complex hydro-meteorological conditions.

5. REFERENCES

- [1] Demin S., Zhukov E., *Ship navigation*, Transport, Moscow, 1991. [in Russian]
- [2] Korn G., Korn T., *A handbook of mathematics for scientists and engineers*, Science, Moscow, 1984. [in Russian]
- [3] Semenov-Tyan-Shansky V., *Statics and dynamics of a ship*, 3rd edition, Shipbuilding, Leningrad, 1973. [in Russian]
- [4] Vagushtenko L. L., Tsimbal N. N., *Automatic ship control systems*, 3rd edition, Translit, Moscow, 2007. [in Russian]
- [5] Sharlay G. N., *Shiphandling*, Students handbook, Vladivostok, 2008. [in Russian]
- [6] Yaroshtuk V. V., *Improvement of methods for the automatic handling of sailing vessels*, Vladivostok, 2013. [in Russian]
- [7] Yaroshuk V. V., *Parameters that take effect to speed of sail ship*, Materials from the Tenth International Yong Scholar's Forum of the Asia-Pacific Region Countries, Far-Eastern National Technical University, Vladivostok, Russia, 25-30 October, 2010.
- [8] Bertram V., *Practical Ship Hydrodynamics*, Oxford, 2000.
- [9] B&G, *Sailing instruments*, URL: <http://www.bandg.com>.
- [10] Garmin Ltd, *Garmin Navigation systems*, URL: <https://www.garmin.ru>.
- [11] Zaichko S. I., *Improving the handling of ships sailing under sail*, Dissertation, Odessa, 2004. [in Russian]
- [12] Dedekam I., *Sail trimming and rigging*, Moscow, 2007. [in Russian]
- [13] Bethwaite F., *High performance sailing*, London, Adlard Coles Nautical, 2010.

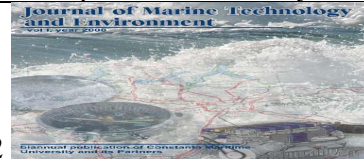

R SCRIPTING LIBRARIES FOR COMPARATIVE ANALYSIS OF THE CORRELATION METHODS TO IDENTIFY FACTORS AFFECTING MARIANA TRENCH FORMATION

Polina Lemenkova

¹Ocean University of China, College of Marine Geoscience, 238 Songling Road, Laoshan, 266100, Qingdao, China,
e-mail address: pauline.lemenkova@gmail.com

Abstract: Mariana trench is the deepest place on the Earth. It crosses four tectonic plates of the Pacific Ocean: Mariana, Caroline, Pacific and Philippine. The formation of the trench is caused by the complex interconnection of various environmental factors. The aim of this study was to describe and characterize various impact factors affecting formation of the Mariana trench geomorphology and continental margin environments using R programming language and mathematical algorithms of correlation methods written on R code. To record the system of geological, tectonic, geographic, oceanological and bathymetric features affecting Mariana trench, a combination of statistical methods, GIS and R programming codes were applied. The questions answered are as follows: which factors are the most influencing for the Mariana trench morphology, and to what extent do they affect its development? Is sedimental thickness of the ocean trench basement more important factors for the trench formation comparing to the steepness slope angle and aspect degree? Three methods of computing were tested: Pearson correlation, Spearman correlation, Kendall correlation, numerical correlogram, correlation matrix and cross-correlations to analyze environmental impact factors. The correlogram matrices are computed and visualized by R scripting libraries. Complex usage of programming tools, mathematical statistics and geospatial analysis enabled to get a differentiated understandings of the hadal environments of the Mariana trench. The results revealed following three types of factors having the highest score: geometric (tg° slope angle), geologic (sedimental thickness) and tectonic structure. The results furthermore indicated that tectonic plates, sedimental thickness of the trench basement and igneous volcanic areas causing earthquakes play the most essential role in the geomorphology of the trench.

Key words: R, programming, statistics, factor analysis, Mariana trench.

1. INTRODUCTION

Mariana trench is a long and narrow topographic depression of the sea floor in the west Pacific ocean, 200 km to the east of the Mariana Islands, located east of the Philippines. It is the deepest part of the Ocean with a maximal depth of $10,984 \pm 25$ m (95%) at $11.329903^\circ N / 142.199305^\circ E$ m at the Challenger Deep [6].

Mariana trench crosses four tectonic plates: Mariana, Caroline, Philippine and Pacific. It has a distinctive morphological feature of the four convergent Pacific plate boundaries, along which lithospheric plates move towards each other. The total length of the trench measures about 2,550 km long approximately.

Various environmental factors affect the geomorphological structure, formation and development of the trench, the most important of which include the following: 1) tectonics: slabs and tectonics plates; 2)

bathymetric features, depth values; 3) geographic location affecting slope aspect degree; 4) geologic structure of the underlying basement and sedimental thickness of the bottom layer. Briefly describe the most important factors below.

2. DESCRIPTIONS OF MARIANA TRENCH

Mariana trench presents a strongly elongated, arched in plan and lesser rectilinear depression stretching for hundreds kilometers and having a narrow depression on the ocean floor with very steep slopes and the depths of 3-5 km width of the bottoms rarely exceeding 5 km in breadth. Its transverse profile is strongly asymmetric: the slopes of the Mariana trench are higher on the side of the island arc. The slopes of the trench are dissected by deep underwater canyons (Fig.1).

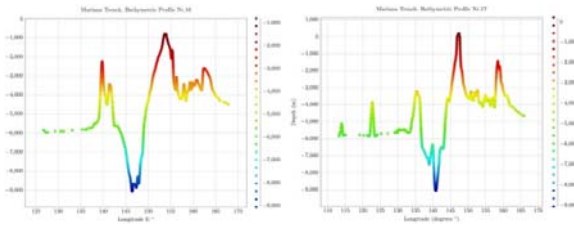
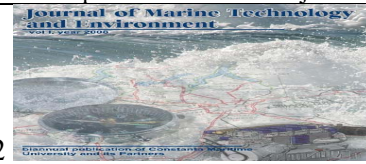

Figure 1 Selected bathymetric profiles of the Mariana trench. Plot visualization: LaTeX.

On the slopes of the trench are also often found various narrow steps. Mariana trench has complicated steps of various shapes and sizes, caused by active tectonic and sedimental processes. The steepness of its geomorphic depth averages in 4-5 degrees (Fig. 2), but its individual parts can be limited to steeper slopes as subjects to the gravitational flow system of the submarine canyons and valleys.

Mariana trench is the largest structural trap located in the continental margins of the Pacific: the sediments are being carrying by the ocean waves in a clockwise direction, passing through the trenches on the west of the Pacific (i.e. the Kermadec Trench and the Tonga Trench. Through the Samoan Passage). They furthermore flow northwest across the equator to the east Mariana.

2.1 Submarine earthquakes

Deep earthquakes are important factors causing system of cracks of the Mariana trench. The occurrence of the deep earthquakes could be explained by various factors. For instance, transformation faulting was proposed as the mechanism for deep earthquakes by [14]. This research is largely based on the basis of experimental observations [14]; [7]; [13]; [4] and involves a shear instability that develops during the incipient transformation of metastable olivine to wadsleyite or ringwoodite.

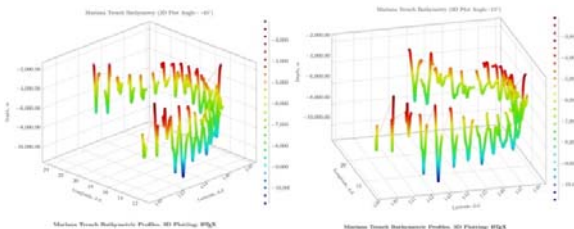

Figure 2 3D-view of the 25 bathymetric profiles of the Mariana trench. Plot visualization: LaTeX.

The horizontal tensional stress during the earthquake shaking triggers development of the system of cracks in the Mariana trench, because the stress

difference under static conditions is caused by the slope inclination. The majority of the cracks within the Mariana trench are open tensile failures and are situated in areas of very gentle slope or horizontal parts of the seabed, in most cases near the edges of steep cliffs which delimit the terraces. There is no lateral nor vertical dislocations on both sides of the cracks, so they are open fractures.

2.2 Tectonic plates subduction

Many physical and chemical processes interact during tectonic plates subduction, and the complexity of the system necessitates an interdisciplinary approach involving seismology, mineral physics, geochemistry, petrology, structural geology, rock mechanics, and geodynamic modeling. For example, phase transformation kinetics determine buoyancy, rates of subduction and, therefore, thermal structure, with the latter feeding back to affect the kinetics. Rheology and therefore large scale slab dynamics may also be affected by mineral transformations and their kinetics.

The rheology of mantle minerals, though having considerable importance in controlling the subduction process, is exceedingly difficult to study experimentally, due to the experimental limitations, since rheology at pressures of the transition zone and lower mantle [12]. An increase of intrinsic density or viscosity with depth as well as phase transitions with a negative Clapeyron slope can all inhibit or delay deep subduction, and the tectonic conditions and the relative motion of the tectonic plates at Earth's surface also play an important role. The effects of subduction of crustal rocks during continental collision consists in following subduction to depths greater than 90km. Slices of continental crust have been exhumed back to the surface very rapidly, thus ensuring the survival of the high-pressure minerals.

2.3 Tectonic slab dynamics

Slab dynamics if one of the important drivers for the trench formation. Effects of slab mineralogy and phase chemistry on the subduction dynamics (buoyancy, stress field), kinematics (rate of subduction and plate motion), elasticity (deformation and seismic wave speed), thermometry (effects of latent heat, isobaric superheating) and seismicity (due to adiabatic shear instabilities) are well discussed [3].

The morphology and development of the subducted slabs are more complex than modeled [5], on either whole mantle flow or convective layering at 660 km depth. Apparently, slabs can deflect horizontally in the upper mantle transition zone beneath some convergent margins whereas penetration to lower mantle depths can occur

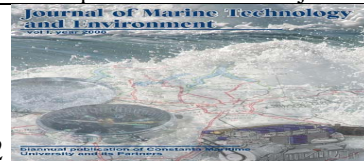

beneath other island arc segments. The different styles of the subduction across the upper mantle transition zone and trench formation.

Not all seismic zones in subducted slabs of the Mariana trench are continuous and that some deep events seem to occur isolated from those at shallower depths. Thus, it is noticed [10] that the continuity of the slab across gaps in the Wadati–Benioff seismic zone between deep earthquake clusters and shallow seismicity and they argue that only the deep earthquakes beneath the north Fiji basin and the deep events beneath New Zealand may occur as detached events with no mechanical connection to the surface. Using the observation and triggering mechanism of high-frequency oceanic “T” waves, [2], it has been argued [8], [9] for the mechanical continuity of most slabs across the deep seismicity gap.

2.4 Deep seismicity

Based on the correlations between strength and temperature, the deep seismicity is likely to result from plastic instabilities, with the distribution of earthquakes being related to strength distribution and therefore slab mineralogy. A complex rheological structure for subducting slabs has been proposed [12], due to the effects of grain size reduction during phase transformations. Based on their model, rapidly subducting and therefore relatively cold slabs should be weaker than slowly subducting warm slabs. Not all seismic zones in subducted slabs are continuous and that some deep events seem to occur isolated from those at shallower depths [10].

As for the structure, magnetism, and dynamics of subduction zones, the continuation of the low wave speed, high attenuation (low Q), and seismically anisotropic wedge are normally near 400 km depth beneath some back arcs. This may be explained by the persistence of hydrous phases to that depth and that magnetic systems are not limited to near-surface regions of the mantle. The correlation also exist between the dehydration of the slab, rupture nucleation and crustal earthquake triggering.

2.5 Seafloor spreading

Processes of the deep-sea terrigenous sedimentation are formed by the transfer of erosion materials from the adjacent land. The main processes are: transportation, deposition and re-deposition of the sedimentation materials. There are two general types of sedimentation in the Mariana trench.

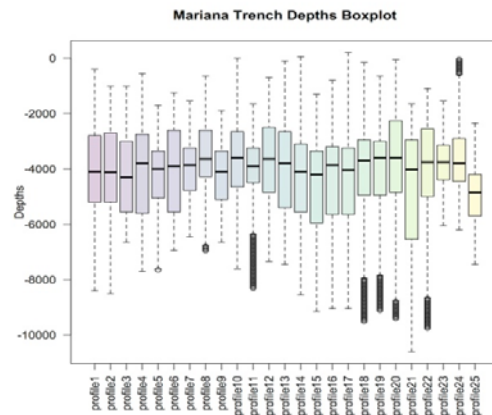

Figure 3 Box plot histograms on data distribution, Mariana trench bathymetric profiles 1:25.

The first one is represented by the pelagic sediments, accumulated as a result of gravitational forces moving suspended matter from the water column into the deeper parts. The second type is represented by the aleurite-clay sediments. In high latitudes they may be mixed with the iceberg sediments. The speed of such terrigenous sedimentation can reach 175-200 mm/thousand years. The most interest have sediments in the bottoms of deep ocean trenches, that mainly accumulate horizontally sand and silt turbidites with gradational stratification.

3. METHODS

3.1. Analysis of bathymetric data distribution by statistical box plots

The created box plot of the depths distribution show summary statistics, that is range and quartiles of the observation points across the bathymetric profiles. A box plot (Fig.3) graphically displays the frequencies of a bathymetric observations data set of the 25 profiles of Mariana trench. It plot the frequency or count, on the depth y-axis (vertical) and the variable being measured on the x-axis, that is profiles (horizontal). The box plot presented in this research (Fig.3) was created by the default R library {stat} graphically representing five the most important descriptive values for a bathymetric data set.

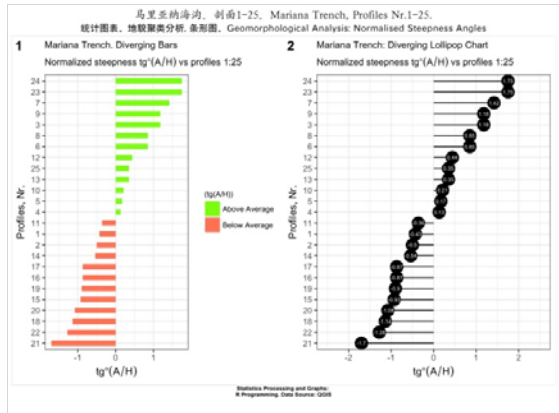

Figure 4 Normalized steepness slope angle, bathymetric profiles 1:25 of Mariana trench.

These values include the following bathymetric values: minimum value, the first quartile (0.25), the median, the third quartile (0.75), and the maximum value (that is, absolute depth). When graphing this five-number summary, only the horizontal axis displays values, while a vertical line is placed above each of the summary numbers showing depth values. A box is drawn around the middle three lines (first quartile, median, and third quartile) and two lines are drawn from the box's edges to the two endpoints (minimum and maximum values of depths).

3.2 Calculation of the normalized steepness angle of the Mariana trench

The normalized steepness was computed as a steepness of dominance hierarchies of slope angle (Fig.4). Steepness is defined as the absolute slope of the straight line fitted to the normalized scores. The normalized scores were obtained on the basis of dominance indices corrected for chance or by means of proportions of wins. Given an observed data set, it computes hierarchy's steepness and estimates statistical significance by means of a randomization test. The following R programming code was used for execution:

```
MDF$profile name <- rownames(MDF) # create new
column for car names
# step-1. Re-calculate argument values (X-axis) into
normalized through the difference between mean and
standard deviation
MDF$norm_tg_angle <- round((MDF$tg_angle -
mean(MDF$tg_angle))/sd(MDF$tg_angle), 2) #
compute normalized tg_angle
# step-2. Distribute values of the normalized argument
into "above" and "below" mean
MDF$angle_type <- ifelse(MDF$norm_tg_angle < 0,
"below", "above") # above / below avg flag
```

```
# step-3. Sort dataframe
MDF <- MDF[order(MDF$norm_tg_angle), ] # sort
# step-4. Values Y (here: profile names) convert them
into factor names
MDF$profile name <- factor(MDF$profile name",
levels = MDF$profile name") # convert to factor to
retain sorted order in plot.
class(MDF$profile name) # check up class
# [1] "factor"
MDF # take a look at new dataframe
# draw 2 plots using dataframe MDF
# step-5. Diverging bars plot
Diverging_Bars <- ggplot(MDF, aes(x = MDF$profile
name", y = MDF$norm_tg_angle, label =
MDF$norm_tg_angle)) +
geom_bar(stat='identity', aes(fill = MDF$angle_type),
width=.5) +
xlab("Profiles, Nr.") +
ylab(expression(tg*degree*(A/H))) +
scale_fill_manual(name="(tg(A/H))",
labels = c("Above Average", "Below
Average"),
values = c("above"="lawngreen",
"below"="coral1")) +
labs(title= "Mariana Trench. Diverging Bars",
subtitle=expression(paste("Normalized steepness
", tg*degree*(A/H), " vs profiles 1:25"))) +
coord_flip() +
theme(plot.title = element_text(size = 10),
legend.title = element_text(size=8),
legend.text = element_text(colour="black", size = 8))
Diverging_Bars
# step-6. Plotting chart
Chart <- ggplot(MDF, aes(x = MDF$profile name", y =
MDF$norm_tg_angle, label = MDF$norm_tg_angle)) +
xlab("Profiles, Nr.") +
ylab(expression(tg*degree*(A/H))) +
geom_point(stat='identity', fill="black", size=6) +
geom_segment(aes(y = 0, x = MDF$profile name",
yend = MDF$norm_tg_angle, xend = MDF$profile
name"), color = "black") +
geom_text(color="white", size=2) +
labs(title="Mariana Trench: Diverging Lollipop Chart",
subtitle=expression(paste("Normalized steepness ",
tg*degree*(A/H), " vs profiles 1:25"))) +
ylim(-2.5, 2.5) +
coord_flip() +
theme(plot.title = element_text(size = 10), legend.title
= element_text(size=8), legend.text =
element_text(colour="black", size = 8))
# step-7. Plot both charts together as one figure
figure <- plot_grid(Diverging_Bars, Lollipop, labels =
c("1", "2"), ncol = 2, nrow = 1)
```

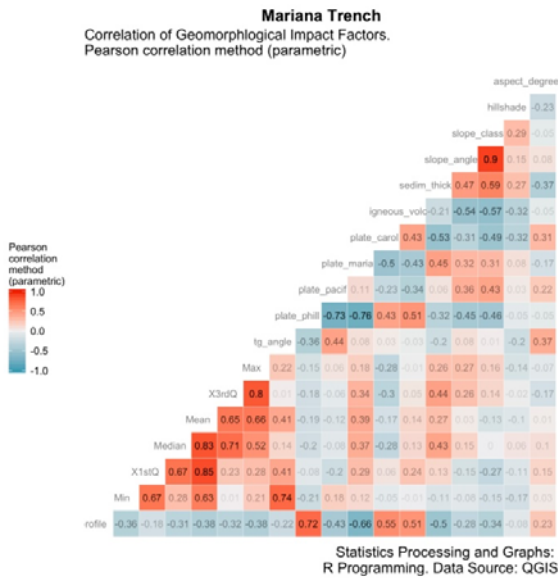
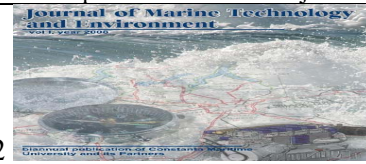



Figure 5 Visualized Pearson correlation for Mariana trench geomorphological impact factors

3.3 Correlation analysis of impact factors

Correlation coefficient is a numerical measure of direction and strength of linear correlation between various environmental variables, i.e. how strong a relationship is between geomorphological, bathymetric and geological variables is across four different tectonic plates.

3.3.1. Computing Pearson correlation

Developed by Karl Pearson from a related idea of Francis Galton in the 1880s, a Pearson product moment correlation coefficient, also known as the bivariate correlation, is a measure of the linear correlation between two variables:

$$r = \frac{\sum(x - mx)(y - my)}{\sqrt{\sum(x - mx)^2 \sum(y - my)^2}} \quad (1)$$

In this case the environmental variables have been tested by the Pearson correlation: sedimental thickness, slope angle, slope class, aspect degree, hill shade in values, location of igneous volcanic zones across the abyssal valley, tectonics by four plates (Mariana, Caroline, Philippine and Pacific), a bunch of bathymetric values, that is maximal and minimal depth values, median means value for each profile, tangens angle degree.

Pearson correlation has a value between +1 and -1, where 1 is total positive linear correlation, 0 is no linear correlation, and -1 is total negative linear correlation. It

has been presented on Fig. 5. It was drawn by calling following R programming script:

```
MDF <- read.csv("Morphology.csv", header=TRUE, sep = ",")
MDF <- na.omit(MDF)
row.has.na <- apply(MDF, 1, function(x){any(is.na(x))})
sum(row.has.na)
head(MDF)
# Check correlation between variables
cor(MDF)
# Visualization of correlations
# Pearson correlation coefficients, using pairwise observations
gp<- ggcorr(data=MDF, method = c("everything", "pearson"),
name = "\nPearson \n correlation \n method \n (parametric)",
label = TRUE, label_size = 2, label_round = 2,
label_alpha = TRUE,
hjust = 0.75, size = 3, color = "grey50", legend.position = "left")
gpt<- gp + labs(title="Mariana Trench",
subtitle = "Correlation of Geomorphological Impact Factors \n Pearson correlation method (parametric)",
caption = "Statistics Processing and Graphs: \n R Programming. Data Source: QGIS") +
theme(plot.title = element_text(family = "Times New Roman", face = 2, size = 12),
plot.subtitle = element_text(family = "Times New Roman", face = 1, size = 10),
plot.caption = element_text(family = "Times New Roman", face = 2, size = 8))
```

In this case the environmental variables have been tested by the Pearson correlation: sedimental thickness, slope angle, slope class, aspect degree, hill shade in values, location of igneous volcanic zones across the abyssal valley, tectonics by four plates (Mariana, Caroline, Philippine and Pacific), a bunch of bathymetric values, that is maximal and minimal depth values, median means value for each profile, tangens angle degree.

3.3.2. Computing Spearman correlation

Named after Charles Spearman, a Spearman non-parametric coefficient is handling ties between the variables less properly comparing to previously computed (see 2.6.1) Pearson coefficient (Fig.6). The Spearman's has been computed on sets of paired rankings between the environmental factors. On the Fig.6 the more correlated variables are represented by the colors of green. The size of the circle also depends on the correlation value.

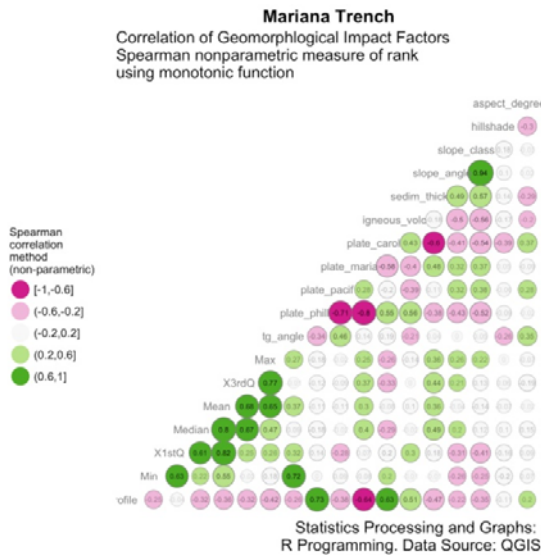

Figure 6 Visualized Spearman correlation ranking for Mariana trench geomorphological impact factors

Spearman’s rank correlation coefficient is denoted by r_s . It is given by the following formula:

$$r_s = 1 - (6\sum d_i^2) / (n(n^2 - 1)). \quad (2)$$

Here d_i represents the difference in the ranks given to the values of the variable for each item of the particular data

The formula of Spearman’s rank correlation coefficient (2) is applied in cases when there are no tied ranks.

Technically, the R programming script for Pearson correlation was changed in case of Spearman by adding following code:

```
gs<-ggcorr(data=MDF, method = c("everything",
"spearman"), geom = "circle", nbreaks = 5,
min_size = 3, max_size = 9, palette = "PiYG",
name = "\nSpearman \ncorrelation \nmethod \n(non-
parametric)",
label = TRUE, label_size = 2, label_round = 2,
label_alpha = TRUE,
hjust = 0.75, size = 3, color = "grey50", legend.position
= "left")
```

Two plots were then plotted together by calling: `figure <- plot_grid(gpt, gst, labels = c("1", "2"), ncol = 2, nrow = 1)`

On Fig. 6 the measure of rank correlation, that is a statistical dependence between the rankings of two environmental variables has been computed using {GGalt} library.

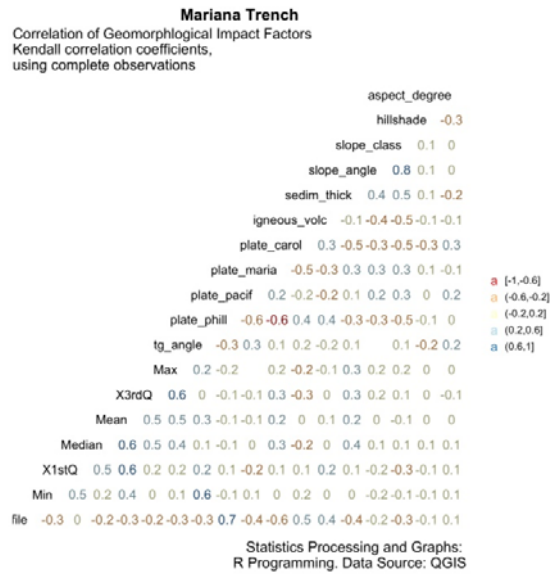

Figure 7 Visualized Kendall tau-correlation for Mariana trench geomorphological impact factors

Spearman correlation shows (Fig.6) how well the relationship between every pair of two environmental variables can be described using a monotonic function and comparing following factors: tectonics, geology, geographic, bathymetric and magmatism. In other words, Spearman's correlation assesses monotonic relationships, whether linear or not between the bunch of available factors. If there are no repeated data values, a perfect Spearman correlation of +1 or -1 occurs when each of the variables is a perfect monotone function of the other.

3.3.3. Computing Kendall correlation

Alike to Spearman coefficient, Kendall tau rank correlation, invented by Maurice Kendall, is also a non-parametric test for statistical dependence between environmental ordinal (or rank-transformed) variables.

Kendall correlation distance is defined as follow:

$$\tau = nc - nd \ 1/2 \ n(n - 1). \quad (3)$$

Kendall rank correlation tau coefficient is a statistically used to measure the ordinal association between two measured quantities, that is environmental factors in this case. Based on the tau coefficient test, a non-parametric hypothesis test for statistical dependence has been computed (Fig.7).

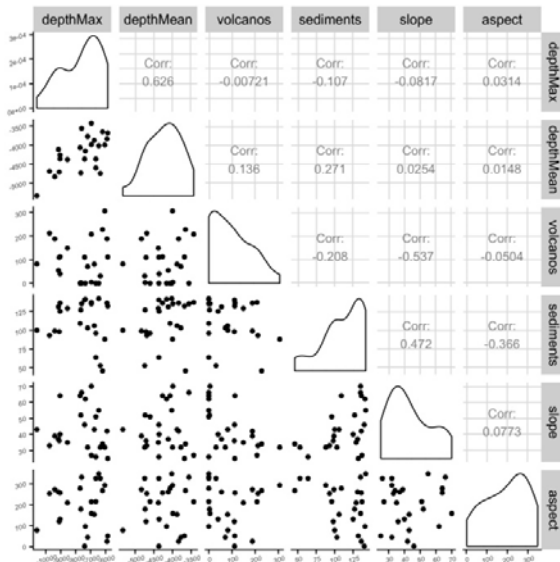

Figure 8 Numerical scatterplot matrix of correlation of the geomorphological impact factors of Mariana trench

It measures a rank correlation: the similarity of the orderings of the data when ranked by each of the quantities. Technically, the script for computing Kendall correlation is as follows:

```
gk<- ggcorr(data=MDF, method = c("complete", "kendall"),
  geom = "text", nbreaks = 5, palette = "RdYIBu", hjust = 1, label = TRUE, label_alpha = 0.4)
gkt<- gk + labs(title="Mariana Trench", subtitle = "Correlation of Geomorphological Impact Factors\nKendall correlation coefficients, \nusing complete observations",
  caption = "Statistics Processing and Graphs: \nR Programming. Data Source: QGIS")
```

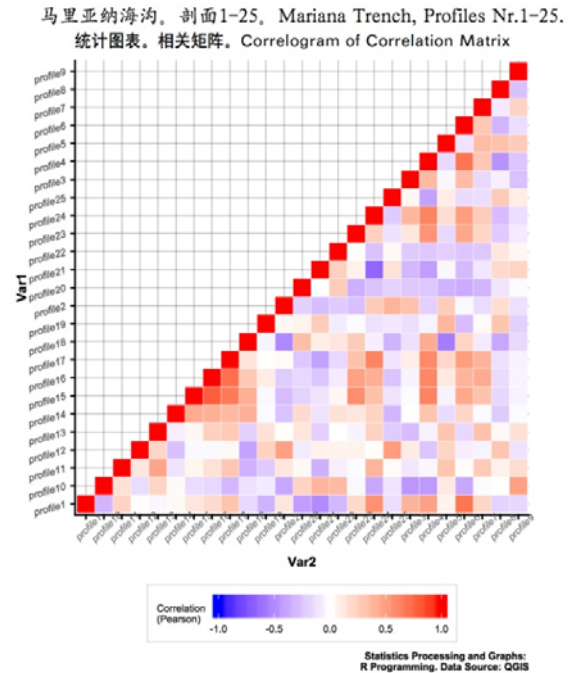

Figure 9 Cross-correlation matrix of the depth values in bathymetric profiles of the Mariana trench

Similar to Spearman coefficient, but unlike Spearman's, can handle ties. Moreover, there are three Kendall tau statistics: tau-a, tau-b, and tau-c, of which tau-b is specifically adapted to handle ties. The tau-b statistic handles ties, i.e., each pair of members of the environmental variables, e.g. tectonics and geological factors, or geographic location and magmatism, or sedimental thickness layer versus closeness of the igneous volcanic spots, – will have the same ordinal value by a divisor term. The latter represents the geometric mean between the number of environmental factor pairs that are not tied on factor one and the number not tied on two. Numerical scatterplot matrix of correlation of the geomorphological impact factors of Mariana trench (Fig. 8) and cross-correlation matrix of the depth values in bathymetric profiles of the Mariana trench (Fig.9) are drawn using R scripting libraries.



3.4. Computing principal component analysis

The Principal Component Analysis (Fig. 10) enabled to visualize eigenvectors as showing major direction and vector length for the principal components affecting the categorical values. Through the PCA a statistical procedure using an orthogonal transformation to convert a set of bathymetric depth observations of possibly correlated variables, has been performed. Thus, the direction of the eigenvectors shows the depth of the Mariana trench has been highly influenced by its geomorphic settings, particularly its location, by 25 profiles, as well as the similarities between the profiles.

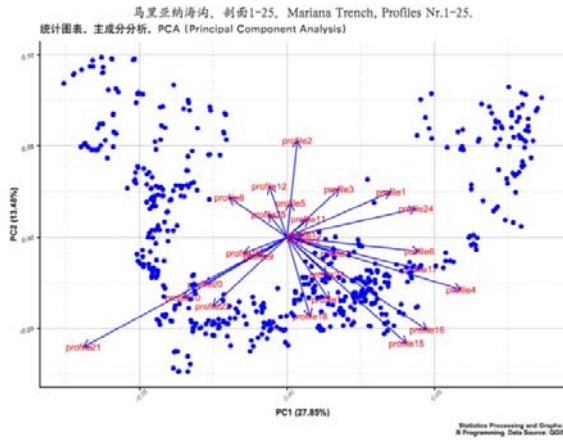

Figure 10 Principal component analysis of correlation of the bathymetric values of profiles of the Mariana trench

4. RESULTS

Current studies revealed that there are factors influencing Mariana trench geomorphic structure the most. The most affecting factors are as follows: sedimental thickness of the basement, slope angle steepness degree, angle aspect, bathymetric factors, such as depth at basement, means, median and minimal values, closeness of the igneous volcanic areas causing possible earthquakes, and geographic location across four tectonic plates – Mariana, Pacific Philippine and Caroline.

Summary of the results is being represented on the Fig. 11 as a hierarchical tree map of impact factors. Mariana trench is an important integral feature of the active continental margins of west Pacific Ocean. Mainland and oceanic sides of the trench have complicated steps of various shapes and sizes, caused by active tectonic and sedimental processes. The steepness of the trench depth averages in 4-5 degrees.

Adjacent tectonic plates, however, have more steep angle with an average slopes of 10 to 15 degrees, but their individual parts can be limited to steeper slopes as subjects to the gravitational flow system of the submarine canyons and valleys. Complex distribution of the various geomorphic material on the adjacent abyssal plains of the ocean contributes to the formation of the geomorphic features of the particular region of the ocean bottom in Mariana trench. It was furthermore found that slope degree and amplitude has important impact on the sedimental thickness, while the aspect degree has lesser effect.

5. CONCLUSIONS

The presented research work focused on the classification of the influencing environmental factors of three main groups (tectonics, bathymetry, geology) affecting formation of the Mariana trench. The research is expected to lead to a significant improvement of our understanding of the relevant influencing geomorphic factors for the analysis of the ocean trenches.

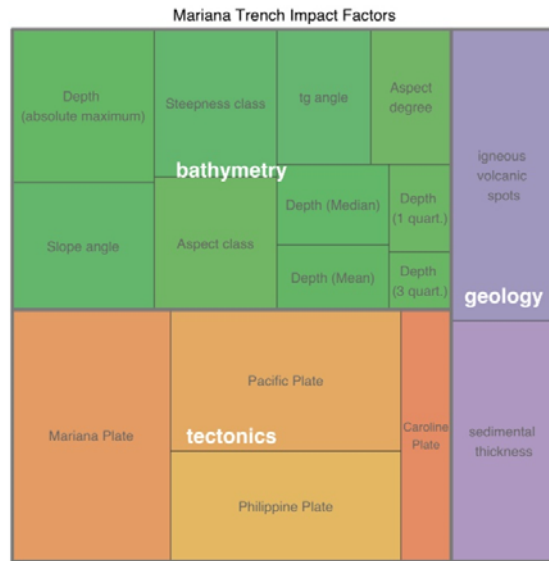

Figure 11 Hierarchical tree map of impact factors affecting formation of the Mariana trench

Additionally, the review of the correlation methods presented in the current research can be applied methodologically for comparing and benchmarking different research schemes on ocean trench analysis. Furthermore it can be used for analysis of submarine earthquake connections with ocean trench formation and



tectonic slab movement (e.g. for the selection of research methods) or the controlling of impact factors during the geospatial analysis.

6. ACKNOWLEDGMENTS

The funding of this research has been provided by the China Scholarship Council (CSC) State Oceanic Administration (SOA), Marine Scholarship of China [Grant # 2016SOA002, 2016].

7. REFERENCES

- [1] Gardner J V, Armstrong A A, Calder B R, Beaudoin J. 2014. *So, how deep is the Mariana Trench?* Marine Geodesy, 37(1): p. 1-13.
- [2] Barazangi, M., Isacks, B., Oliver, J., 1972. *Propagation of seismic waves through and beneath the lithosphere that descends under the Tonga island arc.* Journal of Geophysical Research, 77, 952–958.
- [3] Bina, C.R., Stein, S., Marton, F.C., Van Ark, E.M., 2001. *Implications of slab mineralogy for subduction dynamics.* Physics of the Earth and Planetary Interiors 127 (2001) 1–7.
- [4] Burnley, P.C., Green II, H.W., 1991. *Faulting associated with the olivine to spinel transformation in Mg₂GeO₄ and its implications for deep-focus earthquakes.* Journal of Geophysical Research 96, 425–443.
- [5] Christensen, U.R., 1996. *The influence of trench migration on slab penetration into the lower mantle.* Earth and Planetary Science Letters 140, 27–39.
- [6] Gardner J V, Armstrong A A, Calder B R, Beaudoin J. 2014. *So, how deep is the Mariana Trench?* Marine Geodesy, 37(1): p. 1-13.
- [7] Green II, H.W., Burnley, P.C., 1989. *A new self-organizing mechanism for deep-focus earthquakes.* Nature 341, 733–737.
- [8] Gubbins, D., Snieder, R.K., 1991. *Dispersion of P waves in subducted lithosphere: evidence for an eclogite layer.* Journal of Geophysical Research 96, 6321–6333.
- [9] Hilst van der, R., Seno, T., 1993. *Effects of relative plate motion on the deep structure and penetration depth of slabs below the Izu–Bonin and Mariana island arcs.* Earth and Planetary Science Letters 120, 395–407.
- [10] Isacks, B., Molnar, P., 1971. *Distribution of stresses in the descending lithosphere from a global survey of focal mechanism solutions of mantle earthquakes.* Rev. Geophys. Space Phys. 9, 103–173.
- [11] Karato, S., Riedel, M.R., Yuen, D.A., 2001. *Rheological structure and deformation of subducted slabs in the mantle transition zone: implications for mantle circulation and deep earthquakes.* Physics of the Earth and Planetary Interiors 127 (2001) 1–7.
- [12] Karato, S., Rubie, D.C., 1997. *Towards an experimental study of deep mantle rheology: a new multi-anvil sample assembly for deformation studies under high pressures and temperatures.* Journal Geophysical Research 102, 20111–20122.
- [13] Kirby, S.H., Durham, W.B., Stern, L.A., 1991. *Mantle phase changes and deep-earthquake faulting in subducted lithosphere.* Science 252, 216–225.
- [14] Kirby, S.H., Stein, S., Okal, E.A., Rubie, D.C., 1996. *Deep earthquakes and metastable phase transformations in subducting oceanic lithosphere.* Review Geophysics 34, 261–306.





ENVIRONMENTAL IMPACT OF POLLUTANTS ON SOIL AND SUBSOIL

Mariana PANAITESCU¹ & Fanel-Viorel PANAITESCU²

¹Constanta Maritime University, Engineering Sciences in Mechanics and Environment Field Department, 104 Mircea cel batran Str., 900663, Constanta, Romania, e-mail address: panaitescumariana1@gmail.com

²Constanta Maritime University, Engineering Sciences in Mechanics and Environment Field Department, 104 Mircea cel batran Str., 900663, Constanta, Romania, e-mail address:viopanaitescu@yahoo.ro

Abstract: The paper present details of analysis of soil samples which were contaminated in soil, in rihizosphere areas. Surface samples were collected from a depth of about 0-15 cm. Depth samples were taken from a depth of about 20-40 cm. *Research and methods:* soil samples were taken as „Technical Guidelines on procedures for investigation and assessment of soil and subsoil” issued in accordance with GD. 1408/2007 and Ord. 184/1997. The sample is soil under the influence of soil heavy traffic recreation area, near the intersection Mangalia – Saturn. The indicators which were analysed are:lead, nickel, copper, total chromium, zinc. For each indicator, were analysed, from April to October month, the quantities (in mg/d. s), for 3 types of usage:normal, alert threshold, intervention threshold, for Mangalia - Saturn – Area and for Mangalia - Saturn – Depth. Results: risk matrix and calculations of test solutions. Conclusions: The trend is the accumulation Ni and Cr in all indicators have not exceeded the normal values. Indicators Cu and Zn values determined in general ranks around the normal, with few exceptions below alert threshol..

Key words: impact, contaminats, soil, assessment, traffic, alert, intervention, risk, matrix.

1. INTRODUCTION

The paper present details of analysis of soil samples which were contaminated in rihizosphere areas [1], [2]. Surface samples were collected from a depth of about 0-15 cm. Depth samples were taken from a depth of about 20-40 cm.

2. RESEARCH AND METHODS

In this section we discuss how investigations were made on soil and undersoil [1]. Soil samples were taken as „Technical Guidelines on procedures for investigation and assessment of soil and undersoil” [2], [3]. The sample is soil under the influence of soil heavy traffic recreation area, near the intersection Mangalia – Saturn. The indicators which were analysed are:lead, nickel, copper, total chromium, zinc. For each indicator, were analysed, from April to October month, the quantities (in mg/kg d. s), for 3 types of usage: normal, alert threshold, intervention threshold, for Mangalia – Saturn – Area and for Mangalia – Saturn – Depth.

2.1 Data: soil under the influence of soil heavy traffic recreation area, near the intersection Mangalia-Saturn
 The values of indicators during assessment in this location where: Lead (Table 1, Fig. 1), Nickel (Table 2, fig. 2), Copper (Table 3, Fig. 3), Total Chromium (Table 4, Fig. 4), Zinc (Table 5, Fig. 5).

Table 1: Lead indicator evolution (mg/kg d.s*.).

Usage/ Area	April	May	June	July	August	September	October
Normal	20,000	20,000	20,000	20,000	20,000	20,000	20,000
Alert threshold	50,000	50,000	50,000	50,000	50,000	50,000	50,000
Interventi on threshold	100,00 0	100,00 0	100,00 0	100,000	100,000	100,000	100,000
Mangalia – Saturn Area	84,955	79,595	92,320	99,798	88,948	39,701	35,907
Mangalia – Saturn Depth	13,474	19,967	23,818	22,596	43,918	37,309	20,502

*d.s-dry substance

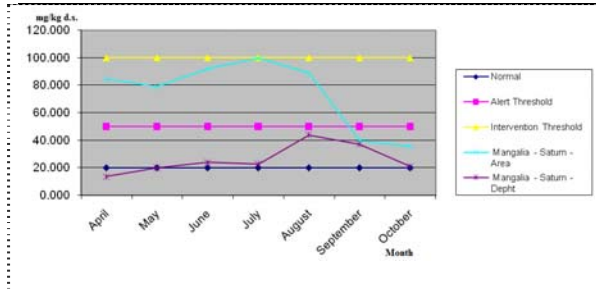
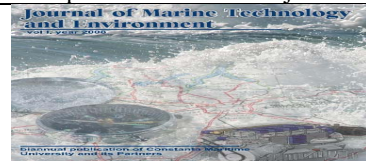

Figure 1 Lead indicator evolution .

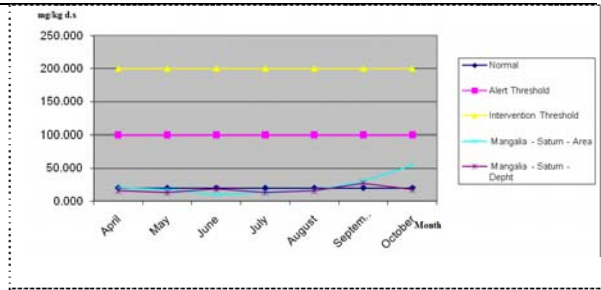

Figure.3 Copper indicator evolution .

Table 2: Nickel indicator evolution (mg/kg d.s.).

Usage/ Area	April	May	June	July	August	September	October
Normal	20,000	20,000	20,000	20,000	20,000	20,000	20,000
Alert	75,000	75,000	75,000	75,000	75,000	75,000	75,000
Intervention	150,000	150,000	150,000	150,000	150,000	150,000	150,000
Mangalia - Saturn - Area	26,172	5,853	19,724	18,337	23,662	29,656	12,570
Mangalia - Saturn - Depth	33,440	7,719	22,196	23,422	21,325	23,953	19,727

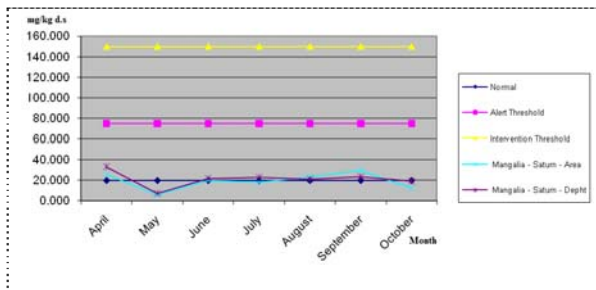

Figure 2 Nickel indicator evolution .

Table 3: Copper indicator evolution (mg/kg d.s.).

Usage/ Area	April	May	June	July	August	September	October
Normal	20,000	20,000	20,000	20,000	20,000	20,000	20,000
Alert	100,000	100,000	100,000	100,000	100,000	100,000	100,000
Intervention	200,000	200,000	200,000	200,000	200,000	200,000	200,000
Mangalia - Saturn - Area	20,758	18,493	10,800	14,403	15,956	29,709	54,501
Mangalia - Saturn - Depth	15,555	13,706	18,714	13,436	15,806	27,688	18,202

Table 4: Total Chromium indicator evolution (mg/kg d.s.).

Usage/ Area	April	May	June	July	August	September	October
Normal	30,000	30,000	30,000	30,000	30,000	30,000	30,000
Alert	100,000	100,000	100,000	100,000	100,000	100,000	100,000
Intervention	300,000	300,000	300,000	300,000	300,000	300,000	300,000
Mangalia - Saturn - Area	31,675	17,740	20,624	10,747	10,521	24,653	27,349
Mangalia - Saturn - Depth	25,157	16,406	18,753	10,295	11,737	18,349	16,748

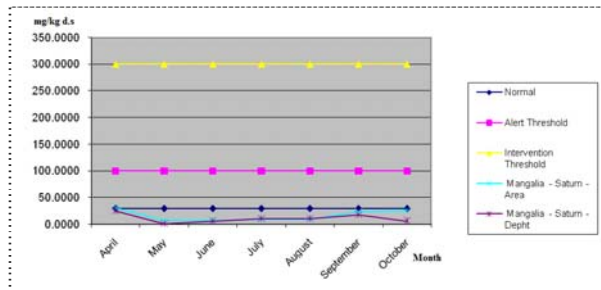

Figure 4 Total chromium indicator evolution.

Table 5: Zinc indicator evolution (mg/kg d.s.).

Usage/ Area	April	May	June	July	August	September	October
Normal	100,000	100,000	100,000	100,000	100,000	100,000	100,000
Alert	300,000	300,000	300,000	300,000	300,000	300,000	300,000
Intervention	600,000	600,000	600,000	600,000	600,000	600,000	600,000
Mangalia - Saturn - Area	151,519	134,606	79,701	34,779	45,429	184,647	199,133
Mangalia - Saturn - Depth	61,789	57,454	57,295	26,562	41,115	197,755	56,192

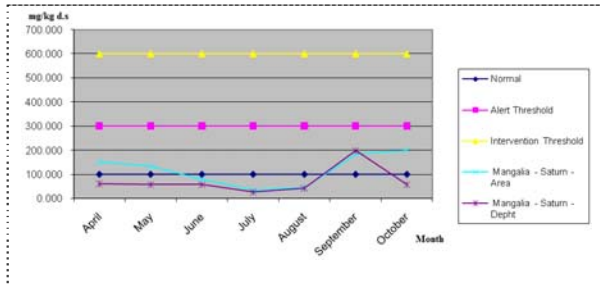
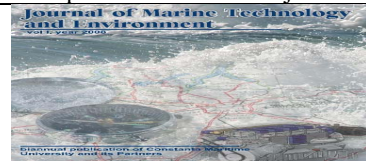

Figure 5 Zinc indicator evolution.

3. RESULTS. RISK MATRIX AND CALCULATIONS OF TEST SOLUTIONS

The risk matrix is presented with standard colours [7]: green is acceptable level (permitted) (risk 1-9), blue is tolerable level (controlled) (risk 10-19), yellow and orange is tolerable with consent (consent for yellow-restricted discretionary and consent for orange-discretionary) and red is intolerable (risk 20-25, consent is noncomplying, prohibited) [8] (Table 6). The results during period from april to october are studied for surface samples and for depth samples. The calculations of test solutions are made for: m-quantity of indicator [kg], c-concentration of indicator [mg/l], u -humidity [%] , k -coefficient of saturation and dry substance concentration C_{ds} [mg/kg d.s.] (Table 6).

Table 6: Zinc indicator

Surface samples										
Month	Indicator	c [mg/l]	[%]rsd	V [l]	Dilution	m [kg]	c mg/kg	u %	$k=100/(100-u)$	C_{ds} [mg/kg d.s.]
April	Lead	0,8615	0,584	0,100	1	0,0012113	71,122	16,283	1,19450052	84,955
May	Lead	0,835	0,743	0,100	1	0,0010606	78,729	1,088	1,010999676	79,595
June	Lead	0,9745	0,805	0,100	1	0,0011376	85,663	7,211	1,077713953	92,320
July	Lead	2,0801	0,423	0,050	1	0,0011198	92,878	6,934	1,074506264	99,798
August	Lead	0,9131	0,586	0,100	1	0,0011161	81,812	8,023	1,087228329	88,948
September	Lead	0,8181	0,654	0,050	1	0,0011040	37,052	6,674	1,071512762	39,701
October	Lead	0,751	0,772	0,050	1	0,0011003	34,127	4,957	1,05215534	35,907
Depth samples										
Month	Indicator	c [mg/l]	%rsd	V, l	Dilution	m, kg	c mg/kg	u, %	$k=100/(100-u)$	C_{ds} mg/kg s.u.
April	Lead	0,2596	1,023	0,050	1	0,0011877	10,929	18,889	1,232878401	13,474
May	Lead	0,2041	0,992	0,100	1	0,0010532	19,379	2,943	1,030322388	19,967
June	Lead	0,2483	1,009	0,100	1	0,0011752	21,128	11,291	1,127281336	23,818
July	Lead	0,4677	0,893	0,050	1	0,0011291	20,711	8,341	1,091000338	22,596
August	Lead	0,4782	0,586	0,100	1	0,0011494	41,604	5,269	1,055620652	43,918
September	Lead	0,7682	0,873	0,050	1	0,0011084	34,654	7,118	1,07663487	37,309
October	Lead	0,2299	1,028	0,100	1	0,0011803	19,478	4,996	1,052587259	20,502
Surface samples										
Month	Indicator	c, mg/l	%rsd	V, l	Dilution	m, kg	c, mg/kg	u, %	$k=100/(100-u)$	c, mg/kg s.u.
April	Copper	0,2105	0,7560	0,100	1	0,0012113	17,378	16,283	1,19450052	20,758
May	Copper	0,1940	0,6750	0,100	1	0,0010606	18,292	1,088	1,010999676	18,493
June	Copper	0,114	0,812	0,100	1	0,0011376	10,021	7,211	1,077713953	10,800
July	Copper	0,3002	0,385	0,050	1	0,0011198	13,404	6,934	1,074506264	14,403
August	Copper	0,1638	0,845	0,100	1	0,0011161	14,676	8,023	1,087228329	15,956
September	Copper	0,6122	0,739	0,050	1	0,0011040	27,726	6,674	1,071512762	29,709
October	Copper	1,1399	0,119	0,050	1	0,0011003	51,800	4,957	1,05215534	54,501
Depth samples										
Month	Indicator	c mg/l	%rsd	V, l	Dilution	m, kg	c mg/kg	u, %	$k=100/(100-u)$	C_{ds} mg/kg s.u.
April	Copper	0,2997	0,8380	0,050	1	0,0011877	12,617	18,889	1,232878401	15,555
May	Copper	0,1401	0,1290	0,100	1	0,0010532	13,302	2,943	1,030322388	13,706

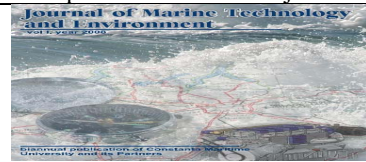

Journal of Marine Technology and Environment Year 2018, Vol.2

June	Copper	0,1951	0,712	0,100	1	0,0011752	16,601	11,291	1,127281336	18,714
July	Copper	0,2781	0,742	0,050	1	0,0011291	12,315	8,341	1,091000338	13,436
August	Copper	0,1721	0,375	0,100	1	0,0011494	14,973	5,269	1,055620652	15,806
September	Copper	0,5701	0,449	0,050	1	0,0011084	25,717	7,118	1,07663487	27,688
October	Copper	0,2041	0,938	0,100	1	0,0011803	17,292	4,996	1,052587259	18,202
Surface samples										
Month	Indicator	c mg/l	%rsd	V, l	Dilution	m, kg	c mg/kg	u, %	k=100/(100-u)	C_{ds} mg/kg s.u.
April	Nickel	0,2654	1,0230	0,100	1	0,0012113	21,910	16,283	1,19450052	26,172
May	Nickel	0,0614	1,9830	0,100	1	0,0010606	5,789	1,088	1,010999676	5,853
June	Nickel	0,2082	1,63	0,100	1	0,0011376	18,302	7,211	1,077713953	19,724
July	Nickel	0,3822	1,116	0,050	1	0,0011198	17,066	6,934	1,074506264	18,337
August	Nickel	0,2429	1,478	0,100	1	0,0011161	21,763	8,023	1,087228329	23,662
September	Nickel	0,6111	0,789	0,050	1	0,0011040	27,677	6,674	1,071512762	29,656
October	Nickel	0,2629	0,845	0,050	1	0,0011003	11,947	4,957	1,05215534	12,570
Depth samples										
Month	Indicator	c mg/l	%rsd	V, l	Dilution	m, kg	c mg/kg	u, %	k=100/(100-u)	C_{ds} mg/kg s.u.
April	Nickel	0,6443	0,6940	0,050	1	0,0011877	27,124	18,889	1,232878401	33,440
May	Nickel	0,0789	1,493	0,100	1	0,0010532	7,491	2,943	1,030322388	7,719
June	Nickel	0,2314	0,695	0,100	1	0,0011752	19,690	11,291	1,127281336	22,196
July	Nickel	0,4848	1,759	0,050	1	0,0011291	21,468	8,341	1,091000338	23,422
August	Nickel	0,2322	1,005	0,100	1	0,0011494	20,202	5,269	1,055620652	21,325
September	Nickel	0,4932	0,593	0,050	1	0,0011084	22,248	7,118	1,07663487	23,953
October	Nickel	0,2212	1,402	0,100	1	0,0011803	18,741	4,996	1,052587259	19,727
Surface samples										
Month	Indicator	c mg/l	%rsd	V, l	Dilution	m, kg	c mg/kg	u, %	k=100/(100-u)	C_{ds} mg/kg s.u.
April	Total chromium	0,3212	1,0340	0,100	1	0,0012113	26,517	16,283	1,19450052	31,675
May	Total chromium	0,1861	0,891	0,100	1	0,0010606	17,547	1,088	1,010999676	17,740
June	Total chromium	0,2177	0,573	0,100	1	0,0011376	19,137	7,211	1,077713953	20,624
July	Total chromium	0,224	1,486	0,050	1	0,0011198	10,002	6,934	1,074506264	10,747
August	Total chromium	0,108	1,743	0,100	1	0,0011161	9,677	8,023	1,087228329	10,521
September	Total chromium	0,508	1,003	0,050	1	0,0011040	23,007	6,674	1,071512762	24,653
October	Total chromium	0,572	0,893	0,050	1	0,0011003	25,993	4,957	1,05215534	27,349
Depth samples										
Month	Indicator	c mg/l	%rsd	V, l	Dilution	m kg	c mg/kg	u, %	k=100/(100-u)	C_{ds} mg/kg s.u.
April	Total chromium	0,4847	0,7740	0,050	1	0,0011877	20,405	18,889	1,232878401	25,157
May	Total chromium	0,1677	0,925	0,100	1	0,0010532	15,923	2,943	1,030322388	16,406
June	Total chromium	0,1955	1,203	0,100	1	0,0011752	16,635	11,291	1,127281336	18,753
July	Total chromium	0,2131	1,142	0,050	1	0,0011291	9,437	8,341	1,091000338	10,295
August	Total chromium	0,1278	1,119	0,100	1	0,0011494	11,119	5,269	1,055620652	11,737
September	Total chromium	0,3778	0,739	0,050	1	0,0011084	17,043	7,118	1,07663487	18,349
October	Total chromium	0,1878	1,218	0,100	1	0,0011803	15,911	4,996	1,052587259	16,748



Surface samples										
Month	Indicator	c mg/l	%rsd	V, l	Dilution	m kg	c, mg/kg	u, %	k=100/(100-u)	C _{ds} mg/kg s.u.
April	Zinc	0,3073	1,9210	0,100	5	0,0012113	126,847	16,283	1,19450052	151,519
May	Zinc	1,4121	0,274	0,100	1	0,0010606	133,142	1,088	1,010999676	134,606
June	Zinc	0,8413	0,327	0,100	1	0,0011376	73,954	7,211	1,077713953	79,701
July	Zinc	0,7249	0,722	0,050	1	0,0011198	32,367	6,934	1,074506264	34,779
August	Zinc	0,4549	0,948	0,100	1	0,0010887	41,784	8,023	1,087228329	45,429
September	Zinc	3,8049	0,028	0,050	1	0,0011040	172,323	6,674	1,071512762	184,647
October	Zinc	4,1649	0,284	0,050	1	0,0011003	189,262	4,957	1,05215534	199,133
Depth samples										
Month	Indicator	c mg/l	%rsd	V, l	Dilution	m kg	c mg/kg	u, %	k=100/(100-u)	C _{ds} mg/kg s.u.
April	Zinc	1,1905	0,5340	0,050	1	0,0011877	50,118	18,889	1,232878401	61,789
May	Zinc	0,5873	0,929	0,100	1	0,0010532	55,763	2,943	1,030322388	57,454
June	Zinc	0,5973	0,765	0,100	1	0,0011752	50,825	11,291	1,127281336	57,295
July	Zinc	0,5498	0,378	0,050	1	0,0011291	24,347	8,341	1,091000338	26,562
August	Zinc	0,4298	0,434	0,100	1	0,0011035	38,949	5,269	1,055620652	41,115
September	Zinc	4,0718	0,066	0,050	1	0,0011084	183,679	7,118	1,07663487	197,755
October	Zinc	0,6301	0,943	0,100	1	0,0011803	53,385	4,996	1,052587259	56,192

4. CONCLUSIONS

The Lead indicator, all values recorded in surface samples exceed normal values, and the majority placing itself above the alert. Some values approaching the threshold of intervention. Them higher values were observed in the months from June to August, during the summer season when traffic is particularly intense area acasta. Depth samples are typically above the normal but below the alert.

The trend is the accumulation Nickel and Total Chromium in all indicators have not exceeded the normal values. Copper and Zinc indicators values determined in general ranks around the normal [9], with few exceptions below alert threshold.

5. REFERENCES

[1] Dabuleanu C 2010 *J. Sci. Env.Stud.Ses. D* 1 37
 [2] **** Gov. Judgment No. 1403/2007 on the regeneration of areas where soil, basement and terrestrial ecosystems were affected”,

<https://lege5.ro/Gratuit/geydknjzgm/hotararea-nr-1403-2007-privind-refacerea-zonelor-in-care-solul-subsolul-si-ecosistemele-terestre-au-fost-afectate>
 [3] *** „Technical Guidelines on procedures for investigation and assessment of soil and undersoil”,https://xa.yimg.com/ghid_investigare_draft_4_august_2008+pentru+HG+1408.doc
 [4] Eliade Gh, Ghinea L, Ștefanic Gh 1975 *The soil microbiology* (CERES Publish House Bucharest)
 [5] Eliade Gh, Ghinea L, Ștefanic Gh 1983 *Biological bases of soil fertility* (CERES Publish House Bucharest)
 [6] Papacostea P 1976 *The soil biology* (Sci. and Encl.Publish House Bucharest)
 [7] Zamea Gh 1983-1986-1990-1994 *General microbiology treaty* (Romanian Academy Publish house Bucharest) Vol I Vol. II Vol. III Vol. IV Vol.V
 [8] *** Standards New Zealand 2004 *Risk Management Guidelines: companion to AS/NZS 4360:2004* (Standards Australia/Standards New Zealand)
 [9] Saunders W S A 2012 *Innovative land use planning for natural hazard risk reduction in New Zealand. Rev.People, Environment and Planning. Palmerston North Massey. Doctor of Philosophy: 229.*





MARINE CASUALTY ANALYSIS OF BUNKER TANKERS BETWEEN 1966 AND 2017

Coşkan Sevgili¹ & Yusuf Zorba²

¹Dokuz Eylül University, Maritime Faculty, Tınaztepe Campus Buca, Izmir, e-mail address: coskan.sevgili@deu.edu.tr

²Dokuz Eylül University, Maritime Faculty, Tınaztepe Campus Buca, Izmir, e-mail address: yusuf.zorba@deu.edu.tr

Abstract: Marine casualties are very critical issues for both maritime sector and the world. Due to generally large impact of marine casualties, there may be seen serious mortality, loss of property and financial, and environmental problems. The ships which are tanker type have more impact and dangerous on marine casualties because of due to the characteristics of the cargo that they carry. Bunker tankers, which are a type of tankers, are in close operation with the vessels when they serve their services. For this reason, the possibility of involved in a marine casualty of these ships is higher. In this paper, it was aimed to analyzed bunker tanker casualties, circumstances and their results. 204 bunker tanker casualty reports occurring between 1966 and 2017 were analyzed using Statistical Package for the Social Sciences (SPSS) 22.0 package. These reports were provided Information Handling Services (IHS) Markit Maritime Portal. According to analysis results, the most common types of casualties were determined as collision (32.8 %), hull and machinery damage (27.0 %) and wrecked/stranded (22.1 %), respectively. In addition, casualty involving injury or death and environmental pollution rates were found low, while almost half of the casualty reports were reported as serious.

Key words: Bunkering, Bunker Tankers, Marine Casualties.

1. INTRODUCTION

With acceleration globalization and trade, the transportation of goods has become more important. Maritime transportation carries over % 80 of global merchandise trade by volume and over % 70 of value [1]. The necessity of transportation of goods has led to the growth of the world merchant ship fleet both tonnage and number. Also, this growth increases the risk of marine accidents. The management of marine casualty and maritime transportation issues are common concerns of maritime countries. Especially, serious marine casualties are incubus to the world because causing both great economic and life losses, and environmental pollution [2]. In order to prevent marine casualties, national governments and international organizations, especially International Maritime Organization (IMO), make regulations, continuously.

Marine casualties can be defined as an event or sequence of events that has resulted in any of the following and has occurred directly by or in connection with the operation of a ship [3]. There are 16593 marine casualties reported between 2011-2016, and 18655 ships involved these casualties. Accordingg to reports, 5607 persons injured, and 600 persons died within this period [4]. Marine casualties are divided into several categories

based on ‘initial event’ by IMO. These categories are collision, stranding/grounding, contact, fire/explosion, hull failure, machinery damage, damages to ship or equipment, capsizing/listing, missing, accidents with life-saving appliances and others (IMO Casualty Analysis Procedure). According to 2011-2016 casualty reports, navigational casualties which are contact, grounding and collision account for most of all casualties.

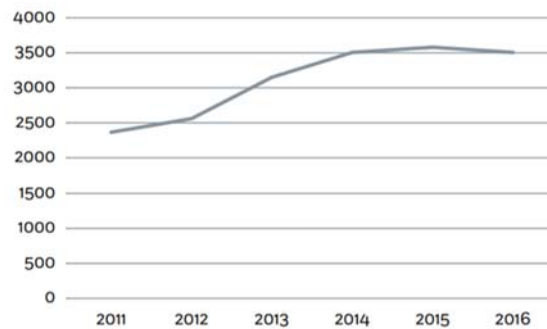

Figure 1 Statistics of Marine Casualties (2011-2016)

Tanker type ships have a higher risk of loss of life and property and environmental problems in marine casualties because of characteristics of their cargo.



Eliopoulou and Papanikolaou [5] determined that navigational casualties were the most occurring marine casualties, and casualties leading to pollution have been an important problem worldwide for tankers.

Bunkering is very crucial for maritime both industry and world trade for the continuity of economic activities. Bunker tankers, which is a type of tanker ships, supply marine fuels to other ships. Although there are other methods of bunkering such as pipeline, truck tanker and railway tanks, bunker barges are the most used method because of flexibility, time saving and capacity advantages. These tankers are divided into three groups that are dumb barges, self-propelled barges (river barges) and coastal tankers (bunker barges) according to technical specifications, hull structures and intended use. While dumb barges used generally in North America have not any self-propelled equipment and need a tugboat for maneuvering and movement at sea, river and bunker barges has their propulsion and machine equipments [6]. In general, capacities of dumb barges, river barges and bunker barges are 160-6400 m³, 400-10000 m³ and 500-20000 m³, respectively [7].

These tankers provide their service either at port area or anchorage area where are usually the most intensive areas of the vessel traffic. In addition, since bunker tankers carry out bunkering operations very close to ships receiving bunker, these operations can have great environmental, material and mortality risks. If environmental risks are examined, bunkering related operations constitute 7 % of marine pollution casualties less than 7 metric tons, and 2% of marine pollution casualties between 7-700 metric tons [8]. In this context, it can be said that the casualties of bunker tankers may be exposed to more environmental pollution risks when pollution from operations is taken into account. When literature is examined, there is a lack of studies on bunkering in spite of mentioned high risks of these operations. In this paper, it was aimed to examine bunker tanker casualties in order to present in detail to stakeholders that are bunker suppliers, bunker brokers, ship owners, charterers and operators.

The rest of paper was organized as follows; in section 2, the literature on marine casualties was examined. Research methodology was explained in section 3, and findings obtained from data were given in section 4. Finally, the paper was finalized with conclusion section.

2. LITERATURE REVIEW

There are many studies on marine casualties in the literature. When these studies examined, it is observed that the studies generally focused on human error in marine casualties [9,10,11,12,13,14,15,16]. On the other hand, while some researchers investigated marine casualties by ship types such as container [17,18], bulk carrier [19,20], passenger [21], fishing [22,23,24,25] and

tanker [5,26,27], others examined more than one or all ship types in their reseraches [2,28,29,30,31].

There are also marine casualty studies on regions. Akten [32] analyzed factors that contribute to marine casualties on Strait of Istanbul, Arslan and Turan [33] investigated marine casualties at the same region using SWOT-AHP method. In addition, Kang et al [34] studied marine casualties causing in Korea, Ventikos et al [35] analyzed on the Aegean Sea, and Sulaiman et al [36] investigated consequences of collision on Langat River located in Malaysia. In addition, Szymankiewicz [37] examined legal aspect of investigating marine accident in Poland pre and post ERIKA III package of EU legislation.

When the studies investigating the tankers are examined, Akten [26] determined that collision and groundings are the most common tanker casualty types at the Strait of Istanbul, and it was pointed out that the risk of casualty is increasing every year with the growth of world trade and the increase in the number of ships. Eliopoulou and Papanikolaou [5] investigated the casualty analysis of large oil tankers whose deadweight are greater than 80000 tonnes between 1978-2003. According to casualty reports, while the most common casualty types are collision and grounding for Aframax, collision and structural failure are leading casualty type for Suezmax, Very Large Crude Carriers (VLCC) and Ultra Large Crude Carriers (ULCC). On the other hand, the types of accident that had the highest severity was found as explosion, grounding and fire, respectively. Ugurlu et al [27] analyzed grounding and collision casualties between 1998-2010 for oil tanker by using fault tree analysis (FTA). It was found that most of the consequences of these types of casualties are economic losses. In addition, death or injury constituted a significant part of the casualty consequences for collision.

3. METHODOLOGY

In the paper, as bunker tanker casualties were examined, casualty reports are obtained from Maritime Portal of IHS Markit that delivers critical analysis and guidance spanning world's the most important business issues such as automotive and maritime [38]. Only the bunker tanker type was chosen when searching for reports in the system. The reports consist of three main sections. In first section, there are several profile information such as name, IMO number, gross tonnage (GRT), deadweight tonnage (DWT), built year, and flag of ships involved the casualties. In section 2, brief informartion about casualty, casualty type and severity, lost of life, missing, status of ship and cargo, pollution occurance and cargo type are given. In last section of report, there are location and zone of casualty, other ship(s) informations if involved casualty and weather conditions.

In total, 204 bunker tanker casualty reports were obtained. The date of bunker casualty reports goes back to 1966, and latest reports belong to the year 2017. In other



words, there are more than 50 years of data in the paper. Each ship was controlled by ship name and IMO number to prevent any mistake. Firstly, obtained data were processed MS-Excel spreadsheet. Later, data were exported to SPSS (Statistical Package for the Social Sciences) software version 26.0 for statistical analyses. Descriptive and chi square analyses were performed to obtained data. The criteria that relate to each other ($p < 0.05$) were explained in the following sections.

4. FINDINGS

When 204 casualty reports of bunker tankers examined, it was determined that there are 143 ships as some ships were involved more than one casualties. The analyzes were given under the headings of the profile information of bunker tankers and characteristics of bunker tanker casualties.

4.1 Profile Information of Bunker Tankers

Casualty year of bunker tankers were between 1966 and 2017 as aforementioned. The year of the most casualty was in 1986 with 13 casualties (6.4 %). 11 casualties (5.4 %) happened in 1983. Also, there was 10 casualties (4.9 %) in 1980 and 1990. It was found that the accidents were concentrated in 1980 and 1992. Casualties occurred between these years (101) constituted almost half of all casualties as seen Figure 2 that shows casualty frequencies by year.

Bunker tankers were often converted from old tankers to bunker tankers in the past years. For this reason, bunker tankers serving were also old. But, bunker tanker are generally new built ships in the present time because of regulations such as double hull requirement. When casualties' data were analysed, the newest bunker tanker was just new building, and she was not even 1-year-old yet, while the oldest was 73 years old. Average age of bunker tankers was determined as 20 years. Also, built year of bunkering tanker involving casualty were between 1914 and 2015, and most of them ship was built year between 1963 and 1980.

Bunker tankers usually have low tonnage because of operational flexibility. When data were examined, the lowest gross tonnage (GRT) was 137, while the biggest bunker tanker had 3128 GRT. Average GRT of bunker tankers were 862.86. It was observed that GRT of bunker tankers were not any localization. The consistent data of deadweight tonnage (DWT) could not be gotten because all DWT of bunker tankers was not obtained in casualty reports.

The flag of bunker tankers was also examined in the paper. 48 different flags were determined in 204 reported casualties. Japanese flagged bunker tankers had the most frequent casualties reported with 30 casualties representing 14.7 % of all casualties. The following flags were found as Greek and UK flagged bunker tankers, and both of them had 19 casualties (9.3 %). Other flags having most frequent casualties were Panama, Russia, Poland and Canada whose frequency were as 18 (8.8 %), 14 (6.9 %), 13 (6.4) and 11 (5.4 %), respectively.

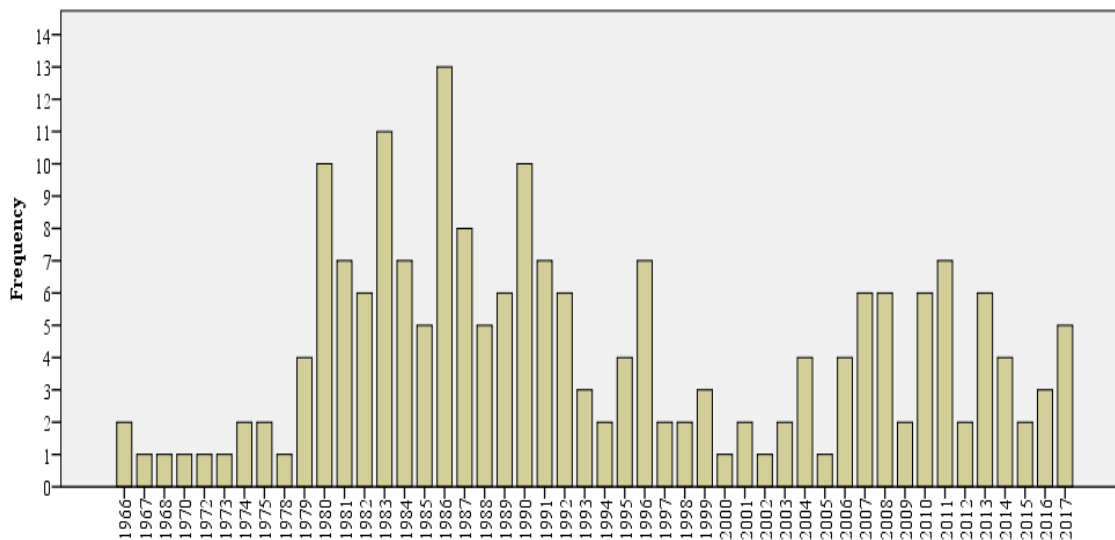

Figure 2 Bunker Tanker Casualty Frequencies by Year.



4.2 Characteristics of Bunker Tanker Casualties

Casualty severities of IHS Markit reports are divided into two categories that are serious and non-serious. For this reason, these categories were utilized in the paper. While 93 casualties were reported as serious, 111 casualties were reported as non-serious.

In casualty reports, there were 8 casualty types that were collision, contact, fire/explosion, foundered, hijacked, hull/machinery damage, war loss and wrecked/stranded (Figure 3). Collision had the highest frequency with 67 casualties (32.8 %). The second most common type of casualty was hull/machinery damage with 55 casualties (27.0 %). There were 45 wrecked/stranded casualties representing 22.1 % of all casualties. Contact and fire/explosion had same frequency with 15 casualties (7.4 %). Frequency of foundered was 5 (2.5 %), hijacked and war loss had same frequency with only one casualty (0.5 %).

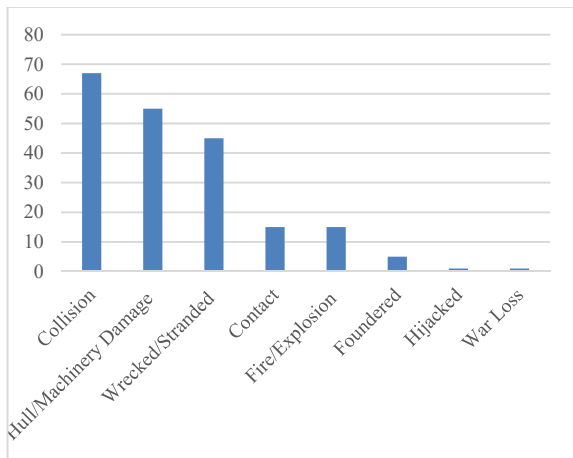

Figure 3 Frequencies of Casualty Types.

While the casualty was happening, 134 bunkering tankers (65.7 %) were on voyage. Also, 28 bunker tankers (13.7 %) were at moored/anchored, and 26 bunker tankers (12.7 %) were on manoeuvring. There were 6 bunker tankers (29 %) that were alongside shore facility, and 2 bunker tankers (1.0 %) were on bunkering. The status of 8 bunker tankers (3.9 %) were unreported in casualty reports. In addition, cargo status of bunker tankers was reported as ‘unknown’ in more than half of casualties. There were 70 full/part loaded, and 27 bunker tanker were empty/ballast.

When casualty areas were examined, the most of casualties representing 56.9 % with 116 casualties were happened at open sea. There were 63 (30.9 %) casualties occurred at ports. There remaining casualties were as follows; 21, 3 and 1 casualty happened on estuary/river, canal and shipyard/ dry dock, respectively.

Casualties mostly took place in North Sea (Europe), Far East (Asia) and West Mediterranean&Black Sea. The casualties given by the regions were translated into the continents. Like as in regional classification, Europe and Asia had most of casualties in continental classification (Figure 4).

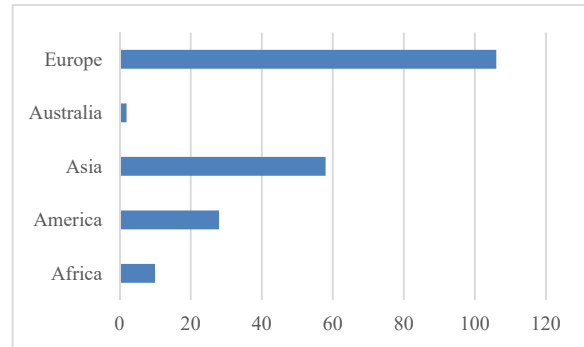

Figure 4 Frequency of Casualties According to the Continents.

The most important negative impacts of marine casualties are on human health/life and environmental. Only 8 casualties (3.9 %) resulted in death or injury. There were not any death or injury in the remaining 196 casualties (96.1 %). According to data, 13 casualties (6.4 %) gave rise to environmental pollution, while 141 casualties (69.1 %) had no environmental impact. The environmental results of 50 accidents are unknown because environmental impact was reported as ‘unknown’ or ‘unreported’. Also, it was determined that time and weather conditions were reported as ‘unreported’ or ‘unknown’ in most of the casualty reports.

After descriptive analyses were conducted, chi-square analyses were examined in order to determine whether there was any association between variables. The analyses that were appropriate for interpretation were explained. Firstly, chi-square analysis was conducted to assess whether cargo status of bunker tanker effects severity of casualty. The test was found to be statistically significant, $X^2(2, n = 204) = 8.431, p = .015$. The severity of casualties of bunker tankers loaded with bunker is more severe than those of empty ones. In the same way, it was founded that there was a statistically significance between cargo status of bunker tanker and environmental impact of casualty $X^2(4, n = 204) = 16.200, p = .003$. Bunker tankers loaded with bunker cause more environmental pollution than empty ones. Also, statistically significance was found between casualty severity and status of casualty to be dead or injured, $X^2(1, n = 204) = 5.896, p = .015$. It is more likely to be dead or injured in casualty reported as serious. Lastly, chi-square analysis was whether there was a



relation between environmental impact of casualty and severity of casualty, and results showed that there was significant difference, $X^2(2, n=204) = 12.287, p=0.002$. Environmental pollution is more frequent in casualties reported as serious.

5. CONCLUSIONS

Marine casualties are nightmares of both marine industry and humanity because of consequences of environmental, human life, and economic losses. Especially, tanker type ships have higher risk in marine casualties due to cargo that tankers carry. In this study, 204 casualty reports between 1966 and 2017 of bunker tankers performing operations in a risky environment were examined.

According to casualty reports, collision, hull/machinery damage and wrecked/stranded constituted the majority of the casualties, respectively. It is seen that these results are in parallel with the studies in the literature. groundings and conflict ship accidents are more frequent in low-tonnage ships. groundings and conflict ship accidents are more frequent in low-tonnage ships, and bunker tankers have also very small tonnage. It can be said that the reason for the high collision frequency is that bunker tankers operate their service very closely with other ships. The reason of the high hull/machinery damage frequency may be high age ratio of bunker tankers whose average is 20. Also, navigational areas of bunker tankers are very close the close, and this situation increases the risk of stranded.

It was determined that the most of the bunker tankers involved in the accident were Japanese flagged, according to recorded reports. Casualties of bunker tanker were concentrate in Europe and Asia. The most of the bunkering operations are carried out in these continents, for this reason, bunkering traffic density and casualty risk is higher than other continents. Rate of death or injury and environmental pollution was found low, while almost half of the casualty reports were reported as serious.

The most important limitation in the study is the lack of information in the reports. Significant portion of data was reported as unreported or unknown, and this situation prevented a more detailed analysis. In addition, only a few investigation reports about bunker tanker casualties have been reached from casualty investigation branches.

It is suggested that risk assessment of bunker tankers would be examined for future studies to determine variables of casualty and reduce casualty risk. Also, operation areas and operational process of bunker tankers can be analyzed in order to identify potential casualty risks of bunker tankers.

6. REFERENCES

- [1] UNCTAD, 2017. United Nations Conference On Trade and Development Review of Maritime Transport 2017. http://unctad.org/en/PublicationsLibrary/rmt2017_en.pdf. Accessed 04.02.2018.
- [2] Chen, J., Zhang, F., Yang, C., Zhang, C., Luo, L., 2017. *Factor and trend analysis of total-loss marine casualty using a fuzzy matter element method*. International Journal of Disaster Risk Reduction, 24, 383-390.
- [3] MAIB, 2012. https://assets.publishing.service.gov.uk/government/uploads/system/uploads/attachment_data/file/386365/Supporting_documents_for_Annual_Report_2013.pdf. Accessed 31.01.2018.
- [4] EMSA, 2017. The Annual Overview of Marine Casualties and Incidents 2017. <http://emsa.europa.eu/emsa-documents/latest/item/3156-annual-overview-of-marine-casualties-and-incidents-2017.html>. Accessed 15.01.2018.
- [5] Eliopoulou, E., Papanikolaou, A., 2007. *Casualty analysis of large tankers*. Journal of Marine Science and Technology, 12(4), 240-250.
- [6] Draffin, N., 2008. *Introduction to bunkering*. Oxford: Petrosport.
- [7] Draffin, N., 2010. *Introduction to bunker operations*. Oxford: Petrosport.
- [8] ITOPF, 2015. The International Tanker Owners Pollution Federation Limited Handbook. http://www.itopf.com/fileadmin/data/Documents/Company_Lit/Members_Handbook_2015_lo.pdf. Accessed: 21.03.2018.
- [9] Celik, M., Cebi, S., 2009. *Analytical HFACS for investigating human errors in shipping accidents*. Accident Analysis & Prevention, 41(1), 66-75.
- [10] Kim, H.T., Na, S., Ha, W.H., 2011. *A case study of marine accident investigation and analysis with focus on human error*. Journal of the Ergonomics Society of Korea, 30(1), 137-150.
- [11] Hänninen, M., Kujala, P., 2012. *Influences of variables on ship collision probability in a Bayesian belief network model*. Reliability Engineering & System Safety, 102, 27-40.
- [12] Chen, S.T., Wall, A., Davies, P., Yang, Z., Wang, J., Chou, Y.H., 2013. *A Human and Organisational Factors (HOFs) analysis method for marine casualties using HFACS-Maritime Accidents (HFACS-MA)*. Safety Science, 60, 105-114.
- [13] Akyuz, E., Celik, M., 2014. *Utilisation of cognitive map in modelling human error in marine accident analysis and prevention*. Safety Science, 70, 19-28.



- [14] Chae, C.J., 2015. *A study on Human Error of DP vessels LOP Incidents*. Journal of the Korean Society of Marine Environment & Safety, 21(5), 515-523.
- [15] Uğurlu, Ö., Yıldırım, U., Başar, E., 2015. *Analysis of grounding accidents caused by human error*. Journal of Marine Science and Technology, 23(5), 748-760.
- [16] Akyuz, E., 2017. *A marine accident analysing model to evaluate potential operational causes in cargo ships*. Safety Science, 92, 17-25.
- [17] Lu, C.S., Tsai, C.L., 2008. *The effects of safety climate on vessel accidents in the container shipping context*. Accident Analysis & Prevention, 40(2), 594-601.
- [18] Kim, D.K., Pedersen, P.T., Paik, J.K., Kim, H. B., Zhang, X., Kim, M.S., 2013. *Safety guidelines of ultimate hull girder strength for grounded container ships*. Safety Science, 59, 46-54.
- [19] Lucas, S.A., Planner, J., 2012. *Grounded or submerged bulk carrier: the potential for leaching of coal trace elements to seawater*. Marine pollution bulletin, 64(5), 1012-1017.
- [20] Bulut, E., Yoshida, S., 2015. *Are Marine Accident Really Accident? Fallacy of Random Marine Accidents in Dry Cargo Fleet*. The Asian Journal of Shipping and Logistics, 31(2), 217-229.
- [21] Yip, T.L., Jin, D., Talley, W.K., 2015. *Determinants of injuries in passenger vessel accidents*. Accident Analysis & Prevention, 82, 112-117.
- [22] Jin, D., Thunberg, E., 2005. *An analysis of fishing vessel accidents in fishing areas off the northeastern United States*. Safety Science, 43(8), 523-540.
- [23] Wang, J., Pillay, A., Kwon, Y.S., Wall, A.D., Loughran, C.G., 2005. *An analysis of fishing vessel accidents*. Accident Analysis & Prevention, 37(6), 1019-1024.
- [4] Perez-Labajos, C.A., Blanco, B., Azofra, M., Achútegui, J. J., Eguia, E., 2009. *Injury and loss concentration by sinkings in fishing fleets*. Safety Science, 47(2), 277-284.
- [25] Kim, W.S., Lee, J.H., Kim, S.J., Kim, H S., Lee, Y.W., 2013b. *A basic study on control factor for the marine casualties of fishing vessel in Korea*. Journal of the Korean society of Fisheries Technology, 49(1), 40-50.
- [26] Akten, N., 2004. *The Bosphorus: Growth of oil shipping and marine casualties*. Journal of Black Sea/Mediterranean Environment, 10(3).
- [27] Uğurlu, Ö., Köse, E., Yıldırım, U., Yüksekıldız, E., 2015b. *Marine accident analysis for collision and grounding in oil tanker using FTA method*. Maritime Policy & Management, 42(2), 163-185.
- [28] Talley, W.K., 2002. *Vessel damage cost differentials: Bulk, container and tanker accidents*. International Journal of Maritime Economics, 4(4), 307-322.
- [29] Yip, T.L., 2008. *Port traffic risks—A study of accidents in Hong Kong waters*. Transportation Research Part E: Logistics and Transportation Review, 44(5), 921-931.
- [30] Eleftheria, E., Apostolos, P., Markos, V., 2016. *Statistical analysis of ship accidents and review of safety level*. Safety Science, 85, 282-292.
- [31] Weng, J., Ge, Y.E., Han, H., 2016. *Evaluation of shipping accident casualties using zero-inflated negative binomial regression technique*. The Journal of Navigation, 69(2), 433-448.
- [32] Akten, N., 2002. *The Bosphorus: Factors contributing to marine casualties*. Journal of Black Sea/Mediterranean Environment, 8(3).
- [33] Arslan, O., Turan, O., 2009. *Analytical investigation of marine casualties at the Strait of Istanbul with SWOT-AHP method*. Maritime Policy & Management, 36(2), 131-145.
- [34] Kang, I.K., Kim, H.S., Kim, J.C., Park, B.S., Ham, S.J., Oh, I. H., 2013. *Study on the marine casualties in Korea*. Journal of the Korean society of Fisheries Technology, 49(1), 29-39.
- [35] Ventikos, N.P., Stavrou, D.I., Andritsopoulos, A., 2017. *Studying the marine accidents of the Aegean Sea: critical review, analysis and results*. Journal of Marine Engineering & Technology, 16(3), 103-113.
- [36] Sulaiman, O.O., Saharuddina, H., Saman, A.B., Wan Nik, W.B., 2011. *Collision damage consequence risk reliability for Langat River (Malaysia) sustainable inland water transportation*. Journal of Marine Technology & Environment, 2.
- [37] Szymankiewicz, D., 2017. *Legal aspects of investigating marine accidents in Poland*. Scientific Journals of the Maritime University of Szczecin, (51), 50-56.
- [38] <https://ihsmarkit.com/index.html> Accessed: 26.03.2018.

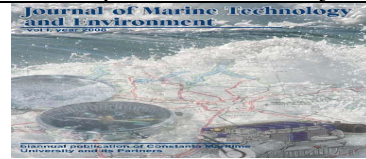

ADVANTAGES AND DISADVANTAGES OF DIFFERENT TYPES OF MODERN MARINE PROPULSIONS

Vasilescu Mihaile – Vlad

Constanta Maritime University, Faculty of Naval Electro-Mechanics, 104 Mircea cel Batran Street, 900663, Constanța, Romania, e-mail vladmihaile_2005@yahoo.com

Abstract: The main focus of this article is the development and use of different types of modern marine propulsions. The main goal is the diversity of energy sources and the reduce of environmental pollution, hoping that this will ensure future energy security supply. I propose to show the advantages and disadvantages of different marine propulsions. The main reason of this article is to try to show a modality for reducing ship pollution and the quantity of fuel used, increasing the energy efficiency, that means, to reduce the price of transportation and a method of saving money for the owners. As a result of my research I discovered that is more convenient to use nuclear propulsion comparing with other conventional types of propulsions. In recent years, a lot of money had been invested in the development and research of security measures for nuclear propulsions, but most of them for military navy of highly developed nations. Nuclear propulsion is particularly suited to ships that need to be at sea for long periods of time without refuelling. Fuel costs are initially paid together with the reactor, initially high, but over time costs are attenuated.

Key words: Pollution; Ship; Nuclear; Diesel; Engine; Power.

1. INTRODUCTION

The article below I will show the advantages and disadvantages of different types of modern marine propulsions.

For both the International Maritime Organization (IMO) and the European Commission, increasing energy efficiency and reducing greenhouse gas emissions for international shipping is a top priority.

For this reason, IMO has adopted two energy efficiency measures: Energy Efficiency Design Index (EEDI) for new ships and Ship Energy Efficiency Management Plan (SEEMP) for all ships.

However, the IMO recognizes the need for further action to reduce greenhouse gas emissions and improve the energy efficiency of ships worldwide.

2. TYPES OF MODERN PROPULSIONS:

- Nuclear propulsion;
- Diesel engine propulsion;
- Propulsion with the steam turbine
- Propulsion with the gas turbine
- Propulsion with electric motors;

2.1 Nuclear propulsion

Nuclear power is particularly suited to ships that need to be at sea for long periods of time without refuelling or for the propulsion of a powerful submarine.

2.1.1. Nuclear reactors

Almost all naval reactors are pressurized water types, which differ from commercial reactors producing electricity in that:

- They deliver a lot of power from a very small volume and therefore run on highly-enriched uranium.
- The fuel is not UO_2 but a uranium-zirconium or uranium-aluminum alloy (c15%U with 93% enrichment) or a metal-ceramic.
- They have long core lives, so that refueling is needed only after 10 or more years, and new cores are designed to last 50 years in carriers and 30-40 years (over 1.5 million kilometers) in most submarines, albeit with much lower capacity factors than a nuclear power plant (<30%).
- The design enables a compact pressure vessel while maintaining safety. For a marine reactor of 4.6 m high and 1.8 m diameter, used for the propulsion of a ship, we need to enclose a core of 1 m high and 1.2 m diameter.

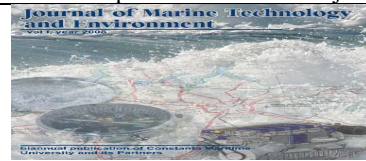

- Thermal efficiency is less than in civil nuclear power plants due to the need for flexible power output, and space constraints for the steam system.
- There is no soluble boron used in naval reactors.

2.1.2 One of the concepts used for nuclear propulsion

The nuclear plant of the ship requires constant cooling, for this reason they use recirculated water. The reactor, pumps, and steam generators are initially circulated with water. The heat emitted from the nuclear reactor is used to heat the water, which is circulated in hollow coils surrounding the reactors. This is done at a very high pressure to prevent the boiling of water at this stage.

The hot water is then transferred to another hollow coil that has water at normal temperature. This produces enormous amounts of steam. The steam generated from the generator is the source of energy for the turbine generators, which make the ship move forward by rotating the propeller of the ship. The steam, after passing through the turbines, is cooled, condensed and then re-circulated to the steam generators by pumps. The enormous amount of heat emitted in the process is the main reason for the nuclear propulsion. Surplus electricity generated in the process is stored in batteries for emergency use and also to meet the electricity requirements on board.

The long-term integrity of the pressure vessel of the compact reactor is maintained by providing an internal neutron shield.

Russia, United States of America, United Kingdom are based on propulsion of steam turbines, while France and China use the turbine to generate electrical power for propulsion.

Russia has invented a submarine with two types of fuel propulsions, a diesel engine and a very small nuclear reactor used for auxiliary power.

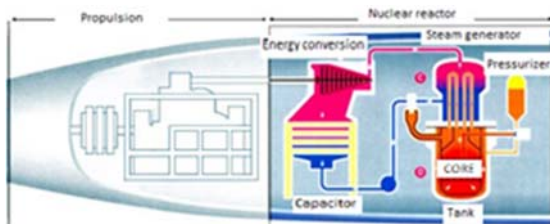

Figure 1 French nuclear power propulsion for a submarine [22]

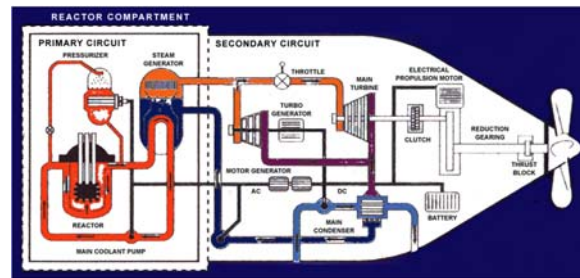

Figure 2 UK nuclear submarine layout [5]

Dismantling nuclear submarines and nuclear ships is a priority and a challenge for the United States of America and Russia. After defueling, normal practice is to cut the reactor section from the vessel for disposal in shallow land burial as low-level waste.

The operation of nuclear propulsion vessels depends mainly on nuclear fission reactions taking place in nuclear reactors.

A nuclear fission reaction involves splitting of the nucleus of an atom to produce smaller nuclei, meaning free neutrons and photons. The atoms once split result in a huge amount of heat-emission and gamma radiation.

2.1.3 Benefits:

- Nuclear propulsion does not emit greenhouse gases harmful to the environment during operation;
- There are many documents that can help construct and maintain a nuclear propelled vessel.
- The concepts of a nuclear power plant are suited to the propulsion of commercial vessels.
- Nuclear propulsion offers more flexibility for commercial ship design and for operational planning of ship speed and body shape;
- High durability.
- Fuel costs are initially paid together with the reactor. Through this eliminating exposure to fluctuations in market prices for significant periods of operation

2.1.4 Disadvantages:

- Implementation of nuclear technology on commercial vessels requires special legislation, as there are still legislative constraints on their design, construction and operation;
- There is a relatively small number of engineers specializing in nuclear propulsion
- It requires a high degree of safety.

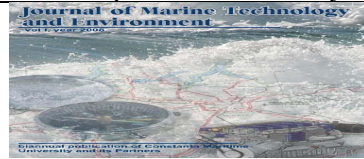

2.2 Diesel engine propulsion



Figure 3 Diesel engine propulsion [23]

2.2.1 Classification of Diesel engines:

- Low speed two-stroke engines;
- Four-speed medium speed engines;
- High-speed four-stroke engines

2.2.2 Global greenhouse gas emissions from diesel engine

From the scheme below we can see the amount of greenhouse gases harmful to the environment from a diesel engine.

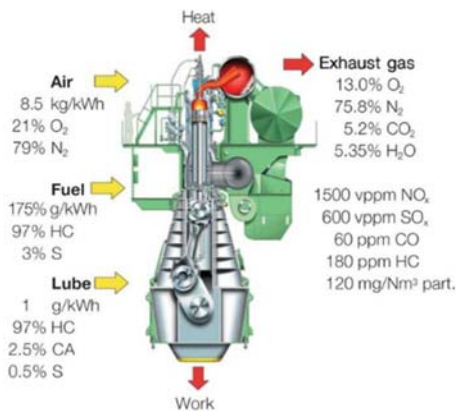

Figure 4 Diesel engine emissions [20]

2.2.3 Benefits:

- The diesel engine technology is well understood and represents a safe form of marine propulsion and auxiliary power.
- Engineer training for operating a diesel engine is well known and exists facilities for appropriate levels of education.

- Engines manufacturers have created maintenance workshops and spare parts networks around the world.
- Diesel fuel of all grades is easy to obtain worldwide.
- There are many ways to reduce greenhouse gas emissions.
- There are numerous research and development programs developed by engines builders.
- Diesel engines are generally capable of coping with various types of loads partial, transient and dynamic.

2.2.4 Disadvantages:

- Diesel engines produce CO₂ emissions as well as NO_x, SO_x, volatile organic compounds and suspended particles. They must be constructed in accordance with MARPOL Annex VI.
- SO_x emissions are a consequence of the sulfur content of the fuel used in motor.
- Biofuels must be carefully managed on board ships to avoid possible contamination.
- Far more weight than a gas turbine of the same power
- The high-speed diesel engine has great losses during operation due to friction, especially during partial loads.
- High fuel consumption if used at partial, not total capacity.
- High and medium speed diesel engines must be coupled to a gearbox

2.3 Propulsion with the steam turbine

A steam turbine is a device that extracts thermal energy from pressurized steam and uses it to do mechanical work on a rotating output shaft.

2.3.1 Disadvantages:

- Higher fuel consumption than diesel;
- Low energy efficiency compared to diesel engines;
- High costs of introducing a propulsion by means of a steam turbine;
- The turbines have to go at high speed for good energy efficiency.

2.4 Propulsion with the gas turbine

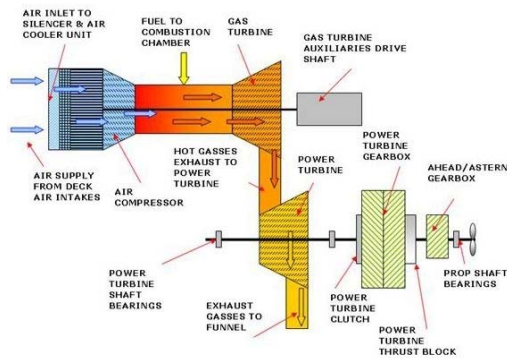

Figure 5 Propulsion with the gas turbine [13]

A gas turbine, also called a combustion turbine, is a type of continuous combustion, internal combustion engine.

2.4.1 Benefits:

- Gas turbines as propulsions systems represent a high level of technology and power.
- Due to the low weight, gas turbines have considerable flexibility.
- They have low NO_x emissions. SO_x emissions are negligible because higher fuel levels are burned.
- Maintenance is based on hours of operation.
- Turbines can be replaced relatively easily.

2.4.2 Disadvantages:

- Fuel for gas turbines are currently expensive compared to conventional fuels because it is distilled several times.
- Gas turbines are less efficient when ambient temperature increases. Less thermal efficiency than similar diesel engines

2.5 Propulsion with electric motors

- Azimuthing Podded Drive– Azipod

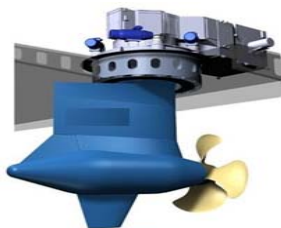

Figure 6 Azipod [11]

- Shaft propeller

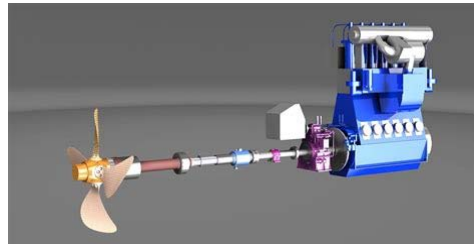

Figure 7 Shaft propeller [9]

- POD

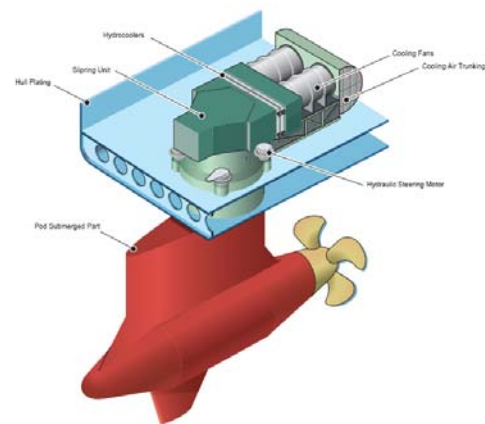

Figure 8 POD [11]

2.5.1 Benefits:

- Effective engines with low energy losses.
- Low greenhouse gas emissions.
- Small size and weight.
- Flexible propulsion technology.
- High hydrodynamic efficiency of the propeller.
- Reduced cavitation risk.
- Low sound level.
- Low level of vibration.
- Variety of electrical charge.
- High energy efficiency - for ships traveling at low or medium speeds.
- High reliability.

2.5.2 Disadvantages:

- It depends on a cooling system.
- High Implementation Costs.
- Low energy efficiency for high-speed ships at all times due to energy losses.
- High Costs with training the crew with a new system, requiring high automation.

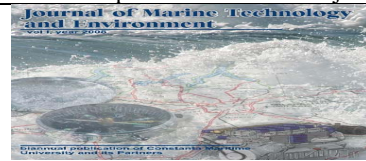

3. TECHNOLOGIES DEVELOPED TO IMPROVE ENERGY EFFICIENCY

3.1 Propulsion with a hybrid diesel engine and an electric motor

The combination of mechanical power, delivered by diesel engines and electric power, supplied by electric motors, provides a high propulsion power for a ship with a wide operating capacity, providing the right power and a torque to the propeller, regardless of how it works.

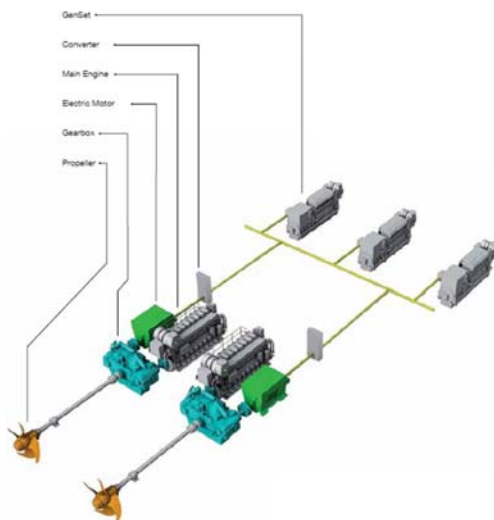

Figure 9 Schematic diagram of a MAN Diesel & Turbo hybrid engine [10]

3.1.1 I consider that the advantages of a hybrid propulsion system would be:

- Large variation of the appropriate operating modes for a flexible energy demand, low speed operation but also high speed operation. The system has a high operating capacity with a low response time and high plant flexibility.
- The engine can be driven both by the diesel engine and / or the electric motor, resulting in a high, redundant and reliable propulsion system.
- In hybrid mode, the diesel engine and propeller can operate with a variable rpm (combined mode), and the frequency and network voltage are fixed and stable.
- Reducing the ship's operating costs due to the possibility to operate both the main engine and the separate auxiliary generators with minimum fuel consumption.
- Small fuel consumption.
- Reduced greenhouse gas emissions of SO_x and CO₂.

- The electrical mode of operation increases the drive capacity and increases the flexibility.
- The electric mode of operation is silent, because of the reduced cavity on the propeller, being operated at an optimum level.
- Depending on the operating modes of the ship, the main engines and auxiliary engines operate less hours per year, thereby reducing the maintenance period.

3.2 Diesel engine with a common rail electronic control system

The world's most powerful common-rail engine is Sulzer 12RT-fl ex 96C.

The use of common-rail fuel injection engines is used because it has a fully integrated electronic control system based on high-performance computers that allows the optimal use of common-rail injection.

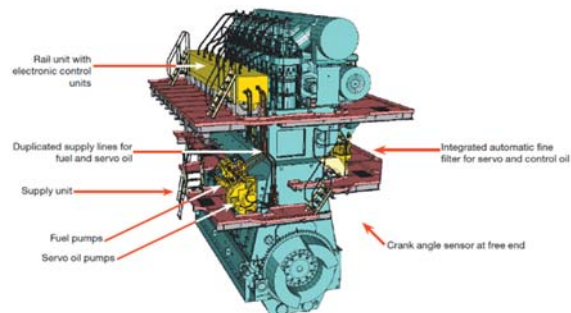

Figure 10 Principal elements of the common-rail system on a Sulzer RT-fl ex engine [11]

3.2.1 The role of the common-rail system

RT-fl ex engines are equipped with the common-rail system for:

- to heat the fuel at a pressure up to 1000 bar.
- bring servo oil to pressures up to 200 bar.
- control the oil at a constant pressure of 200 bar.
- to control the air system used to start the engine.

3.2.2 Advantages of the Sulzer RT-fl system:

- Volumetric accurate fuel injection control with integrated security.
- Variable injection velocity and variable injection pressure.
- Independent drive and individual shut-off of the individual fuel injection valves.
- Ideal for use with heavy fuel.

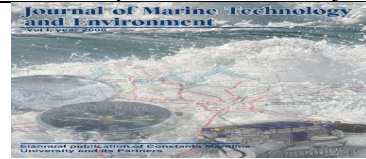

- Fuel injection valves.
- Common high efficiency pumps.
- Low vibration level.
- Low level of internal forces and moments.
- Constant operation at very low speeds with precise speed adjustment.
- Smoke-free operation at all speeds.

3.3 Combined Naval Propulsion: Steam Turbine & Gas Turbines

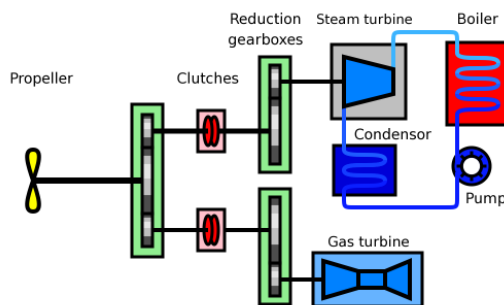

Figure 11 Combined Naval Propulsion: Steam Turbine & Gas Turbines [19]

3.3.1 Disadvantages:

- High complexity.
- It occupies a very large space.
- High costs.

3.4 Propulsion with hydrogen

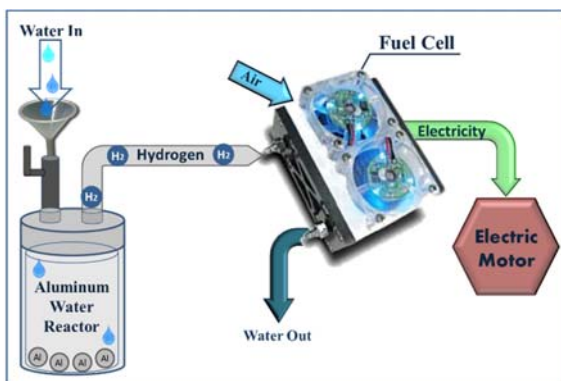

Figure 12 Propulsion with hydrogen [14]

Hydrogen can either be burned in some kind of jet engine, or other kind of internal combustion engine, or can be used to power a fuel cell to generate electricity to power a propeller.

3.4.1 Benefits:

- High potential in medium and long term.
- Environmentally friendly, it does not generate CO₂ or Sox.
- Uses sources of terrestrial energy for creation. Hydrogen can be used in combustion cells and internal combustion engines
- Burning produces fresh water.
- It will still be available when fossil fuels are exhausted.
- It is the tenth largest element of the earth and is the most abundant element in the universe.
- It is generated from water and returns to water when it is burnt.
- It is available in vast quantities from the world's oceans.
- It can be used in combustion cells to generate electricity
- It can be used as a fuel in internal combustion engines to replace gasoline or diesel.
- It contains three times more energy than the energy from the combustion of hydrocarbon fuels.
- It's invisible, odorless and non-toxic

3.4.2 Disadvantages:

- It requires an expensive infrastructure.
- Creating hydrogen is expensive.
- It requires special legislation due to safety issues.

4. ANALYSIS COST OF FUELS

Analysing the diagram below, we can see that the price of nuclear energy over the years has almost stagnated, increasing very little at very long intervals. At the same time, we can see that the price of fossil fuels has risen sharply over time.

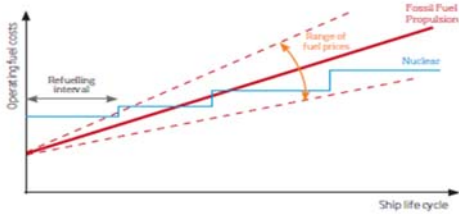
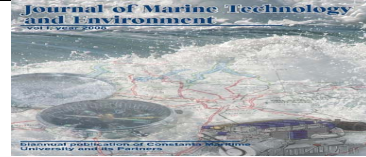

Figure 13 Analysis cost of fuels [24]

5. CONCLUSIONS

By putting in balance all the types of propulsions studied in this report, I have concluded that the best, most efficient, consuming in a long period of time, with high initial implementation costs but in time proving to be cheap comparing with other types of fuels, environment-friendly source of energy while kept under control, but still needing a deeper development and analysis would be nuclear power.

6. REFERENCES

[1] ARTISIUK Vladimir, "SMR Technology Development in Russia and Capacity Building Supports for Embarking Countries", Tunis, Tunisia, October 2017.
[2] DARTE Filipe, GONCALO Gonçaves, NUNO Fonseca, TIAGO Farias, "The Hydrocat Project – An all electric ship with photovoltaic panels and hydrogen fuel cells"; World Electric Vehicle Journal Vol. 3; Norway, 2009.
[3] POLV Olgaard, REINSTAD Ole, "Russian Nuclear Power Plants for Marine Applications", NKS, April 2006.

[4] RAGHEB M. "Nuclear Marine Propulsion", Oxford, Great Britain, 2018.
[5] TSVETKOV P., "Nuclear Power - Deployment, Operation and Sustainability", In Tech, Russia, 2011.
[7] TSICHLIS Philip Tsichlis, "Ship Energy Efficiency Management", Naval Architect & Marine Engineer, Great Britain, 2017.
[8] "Ship Energy Efficiency Measures- Status and Guidance"; ABS, Great Britain, 2018.
[9] "Future Ships Powering Options- Exploring alternative methods of ship propulsion"; Royal Academy of Engineering, Great Britain, 2013.
[10] "Hybrid Propulsion", MAN Diesel & Turbo, Germany, 2017.
[11] "The Sulzer RT-flex Common-Rail System Described", Wärtsilä Switzerland Ltd, Switzerland, 2004.
[12] "Man B&W G95ME-C9.5", MAN B&W, Germany, 2018.
[13] <https://www.brightengineering.com>
[14] <https://frpc.net.technion.ac.il>
[15] <https://www.gepowerconversion.com>
[16] <https://www.marine.man.eu>
[17] <http://marinenotes.blogspot.com>
[18] <https://www.mpoweruk.com>
[19] <https://www.svlele.com>
[20] <https://slideplayer.com>
[21] <https://www.wartsila.com>
[22] <https://www.world-nuclear.org>
[23] <https://www.marineinsight.com>
[24] <https://www.wikipedia.org>

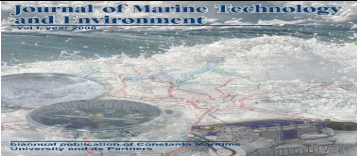

PUBLISHED SINCE 2008
ISSN:1844-6116
ON LINE SINCE: 2008
PUBLISHED BY: Editura Nautica/ Constanta Maritime University